

**BOM:50208066**

| ITEM # | QTY. | PART #   | DESCRIPTION                       | WEIGHT |
|--------|------|----------|-----------------------------------|--------|
| 1      | 2    | 50201129 | STAKKABOX CONNECT HS RIGHT 1200mm | 5.8    |
| 2      | 2    | 50201123 | STAKKABOX CONNECT HS RIGHT 800mm  | 4.8    |
| 3      | 4    | 50201133 | STAKKABOX ULTIMA PEG              | 0.22   |

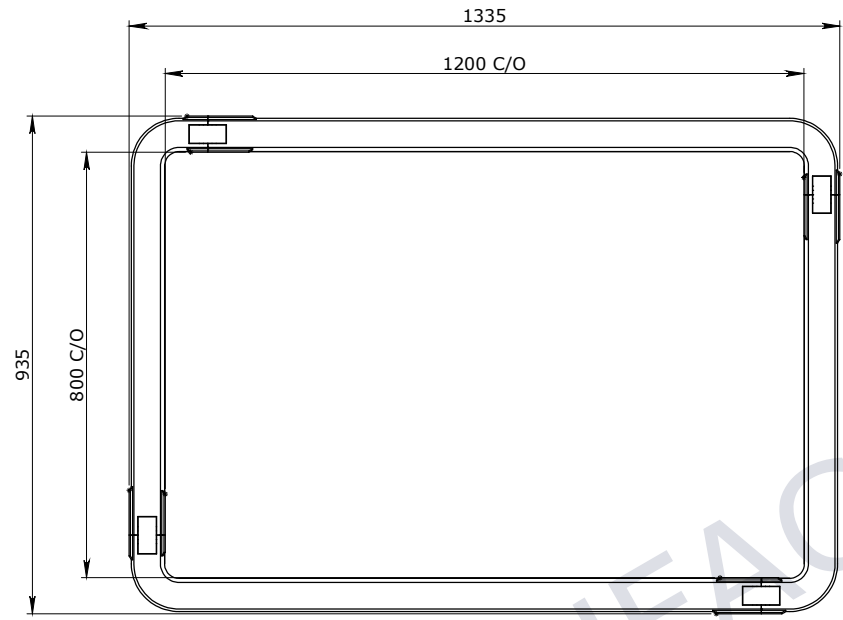

PLAN VIEW

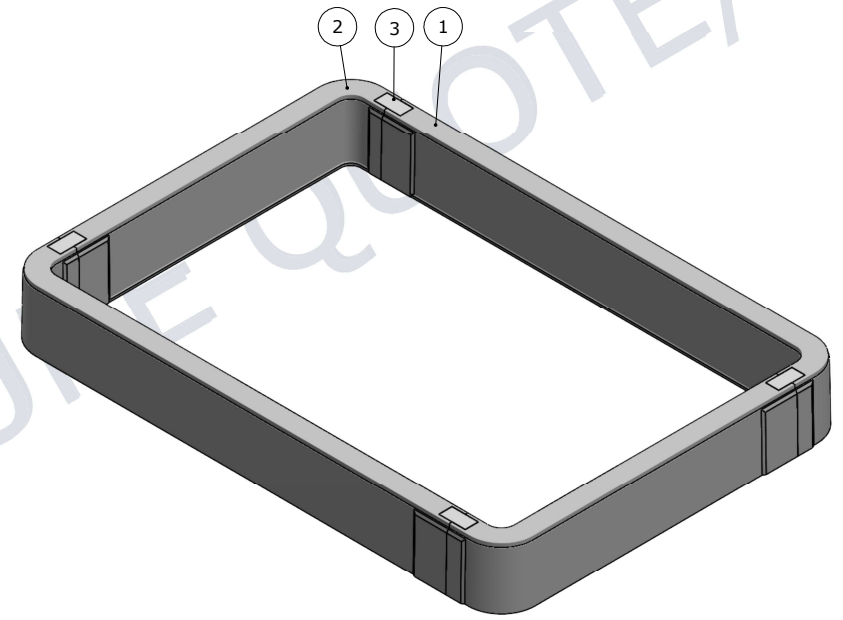

ISOMETRIC VIEW



ELEVATION VIEW

UNCONTROLLED DOCUMENT WHEN PRINTED

- TOLERANCE NOTES:**
1. CONCRETE TOLERANCES TO BE IN CONJUNCTION / ACCORDANCE WITH AS3600 - CONCRETE STRUCTURES
  2. WHEN A BROOM FINISH IS REQUIRED THE GENERAL TOLERANCE SUPERCEDES THE FLATNESS TOLERANCE
  3. WALL THICKNESS - DIMENSION AS NOTED IS MINIMUM THICKNESS ONLY
  4. CONCRETE GRADE - 40MPA UNLESS NOTED OTHERWISE
  5. DIMENSIONS ARE NOT INCLUSIVE OF SEALANTS OF JOINTS
  6. SURFACE FINISH - CLASS 4 (AS3610.1)

| Rev. | DESCRIPTION | DATE | BY | APPROVED |
|------|-------------|------|----|----------|
| 3    |             |      |    |          |
| 2    |             |      |    |          |
| 1    |             |      |    |          |

| GENERAL TOLERANCES |              | REVISION CONTROL                     |  |
|--------------------|--------------|--------------------------------------|--|
| NOMINAL:           | UP TO 1000mm | 1M AND ABOVE                         | FLATNESS: (NOT INCLUDING BROOM FINISH) |
| TOLERANCE:         | ±5mm         | 1mm IN 200mm UP TO A MAXIMUM OF 20mm | ±4mm PER 1M WIDTH IN 1M LENGTH         |

|                         |                  |
|-------------------------|------------------|
| CHK / APPR:<br>Lee, Mia | WEIGHT:<br>24Kg  |
| DATE:                   | MATERIAL:<br>SMC |
| RPEQ DOCUMENT #:        | TRF REF:         |

**Infrastructure Products Australia**  
A CRH COMPANY

HEAD OFFICE:  
1 REEVES COURT  
BREAKWATER, VIC 3219  
1800 065 356

ENGINEERING & DEVELOPMENT:  
91 STRADBROKE STREET  
HEATHWOOD, QLD 4110  
(07) 3714 0444

|  |   |                       |                  |
|--|---|-----------------------|------------------|
| DRAFTED DATE:<br>20/03/2024                                      | PARTY/PRODUCT #<br>50208066                 | QUOTE #               | ORDER #          |
| DRAFTED BY:<br>M.LEE   | REINFORCEMENT COMPUTATION                   | PIT #                 | ITEM TYPE        |
| DATE LAST SAVED:<br>25/03/2024                                   | CLIENT<br>INFRASTRUCTURE PRODUCTS AUSTRALIA |                       |                  |
| LAST SAVED BY:<br>MLEE   | PROJECT DESC<br>CATALOGUE PRODUCTS          |                       |                  |
| DRAWING NAME<br>KIT STAKKAbOX™ ULTIMA RING RIGHT HAND 1200x800mm |   | DRAWING #<br>50208066 | REV.<br><b>1</b> |
| DRAWN TO AS 1100<br>DO NOT SCALE<br>FROM SHEET                   | PAGE<br>1 / 1                               | SHEET SIZE<br>A3      | SCALE<br>1:10    |