

**FIBRE CONCRETE PRODUCT NOTE:**

- REFER TO GENERAL TOLERANCES UNO
- 40MPa FIBRE REINFORCED CONCRETE (FIBRECON MP47@5Kg/M<sup>3</sup>)
- ALL LIFTING POINTS TO BE USED WHEN LIFTING
- MINIMUM STRENGTH OF CONCRETE SHALL BE 25MPa AT THE TIME OF LIFTING
- COVER TO REINFORCEMENT TO BE 50mm
- REFER TO ANCON LIFTING ARRANGEMENT PLAN

**BOM:50203763-AS1**

ITEM #	QTY.	PART#	DESCRIPTION	WEIGHT
1	1	50203763	PIT CONCRETE BELLTOP 1100X900X1050 CLASS D	1152.78
2	1	50201203	AX S™ SCEC SL1 TO SUIT 1100x900 OPENING COVER GMS	93.7

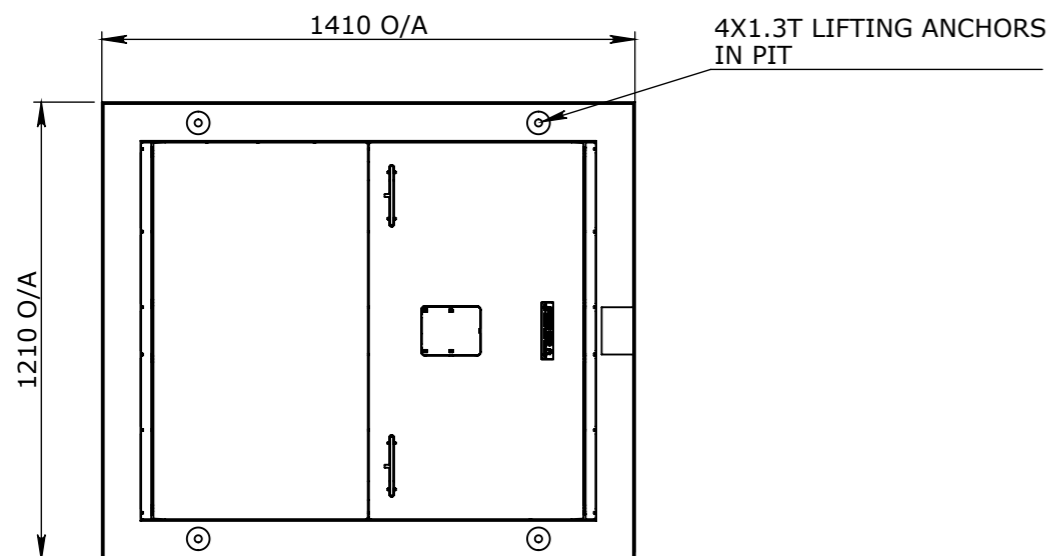

**PLAN VIEW**

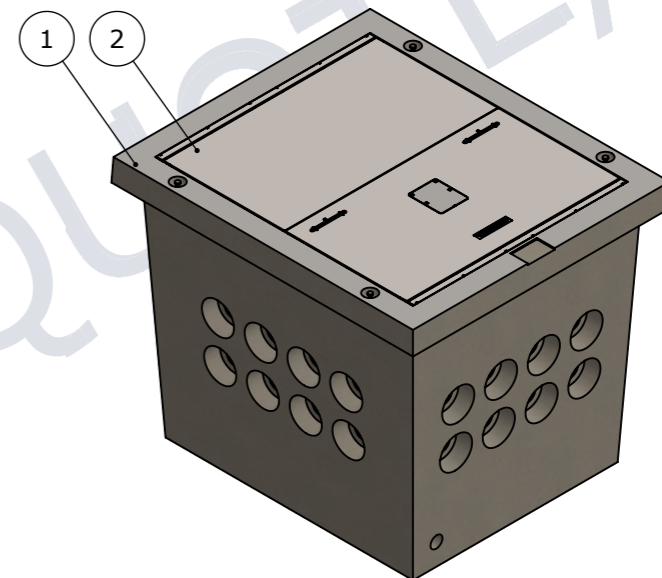

**ISOMETRIC VIEW**  
SCALE\_1:25

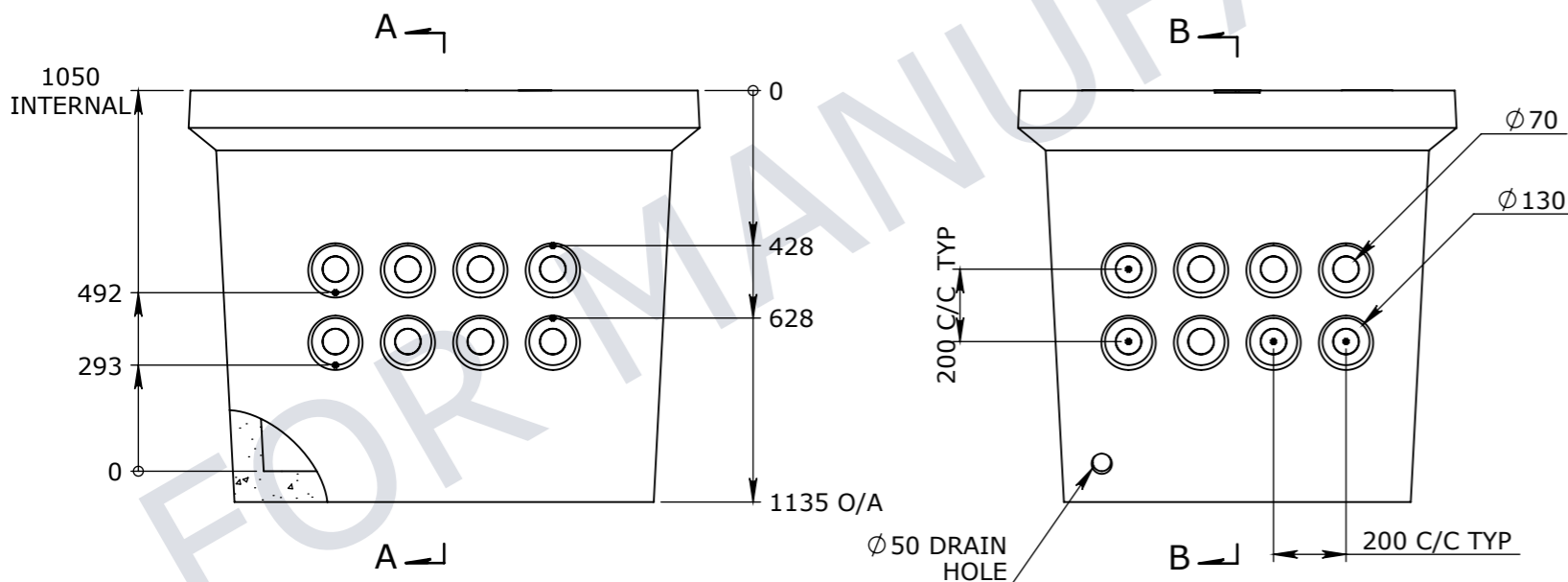

**ELEVATION VIEW**

**END VIEW**

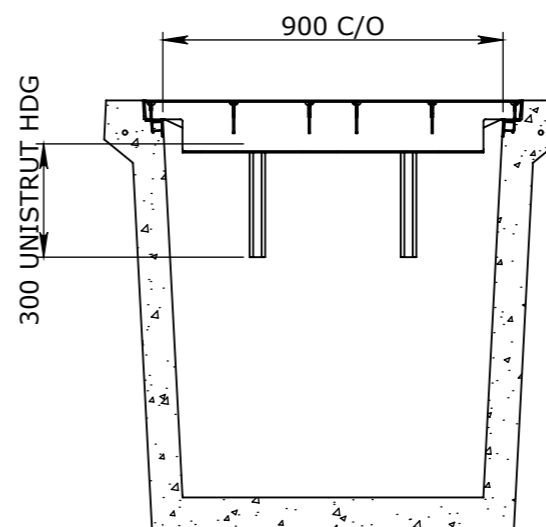

**SECTION A-A**

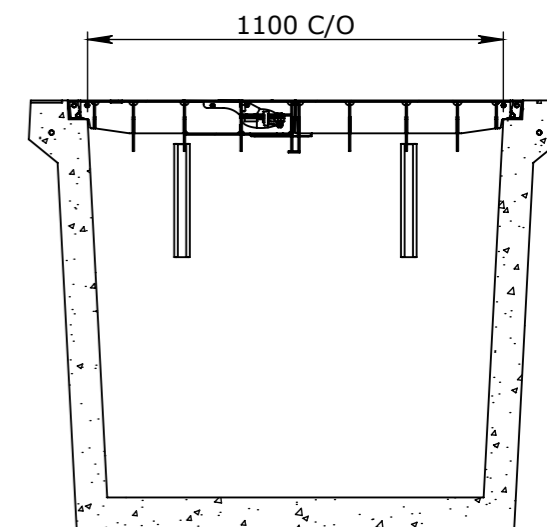

**SECTION B-B**

UNCONTROLLED DOCUMENT WHEN PRINTED

- TOLERANCE NOTES:**
- CONCRETE TOLERANCES TO BE IN CONJUNCTION / ACCORDANCE WITH AS3600 - CONCRETE STRUCTURES
  - WHEN A BROOM FINISH IS REQUIRED THE GENERAL TOLERANCE SUPERCEDES THE FLATNESS TOLERANCE
  - WALL THICKNESS - DIMENSION AS NOTED IS MINIMUM THICKNESS ONLY
  - CONCRETE GRADE - 40MPa UNLESS NOTED OTHERWISE
  - DIMENSIONS ARE NOT INCLUSIVE OF SEALANTS OF JOINTS
  - SURFACE FINISH - CLASS 4 (AS3610.1)

Rev	DESCRIPTION	DATE	BY	APPROVED
3				
2				
1				

GENERAL TOLERANCES		REVISION CONTROL	
NOMINAL:	UP TO 1000mm	1M AND ABOVE	FLATNESS: (NOT INCLUDING BROOME FINISH)
TOLERANCE:	±5mm	1mm IN 200mm UP TO A MAXIMUM OF 20mm	±4mm PER 1M WIDTH MAX IN 1M LENGTH

CHK / APPR:	
DATE:	
RPEQ DOCUMENT #:	
WEIGHT:	1246.5Kg
MATERIAL:	<NOT SPECIFIED>
IRF REF:	

**Infrastructure Products Australia**  
A CRH COMPANY

HEAD OFFICE: 1 REEVES COURT, BREAKWATER, VIC 3219, 1800 065 356  
ENGINEERING & DEVELOPMENT: 91 STRADBROKE STREET, HEATHWOOD, QLD 4110, (07) 3714 0444

DRAFTED DATE:	16/09/2020
DRAFTED BY:	A.CHAO
DATE LAST SAVED:	13/12/2023
LAST SAVED BY:	MLEE
DRAWN TO AS 1100 DO NOT SCALE FROM SHEET	

PART/PRODUCT #	50203763	QUOTE #		ORDER #	
REINFORCEMENT COMPUTATION		PIT #		ITEM TYPE	
CLIENT	CUBIS SYSTEMS/AUSPITS				
PROJECT DESC	CATALOGUE PRODUCTS				
DRAWING NAME	ASSEMBLY 911 SCEC				
DRAWING #	50203763-AS1	PAGE	1 / 1	SHEET SIZE	A3
SCALE	1:20	REV. 0			