

NOTES

- MATERIAL
HS5 RING - HDPE
BASE - UTILITY BASE MIX
- REFER TO STAKKABOX™ MODULA HS5 INSTALLATION GUIDE" FOR INSTALLATION DETAILS

BOM:50201807

ITEM #	QTY.	PART #	DESCRIPTION
1	4	50201805	HS5 RING SECTION, 150MM
2	1		INSITU POURED SLAB

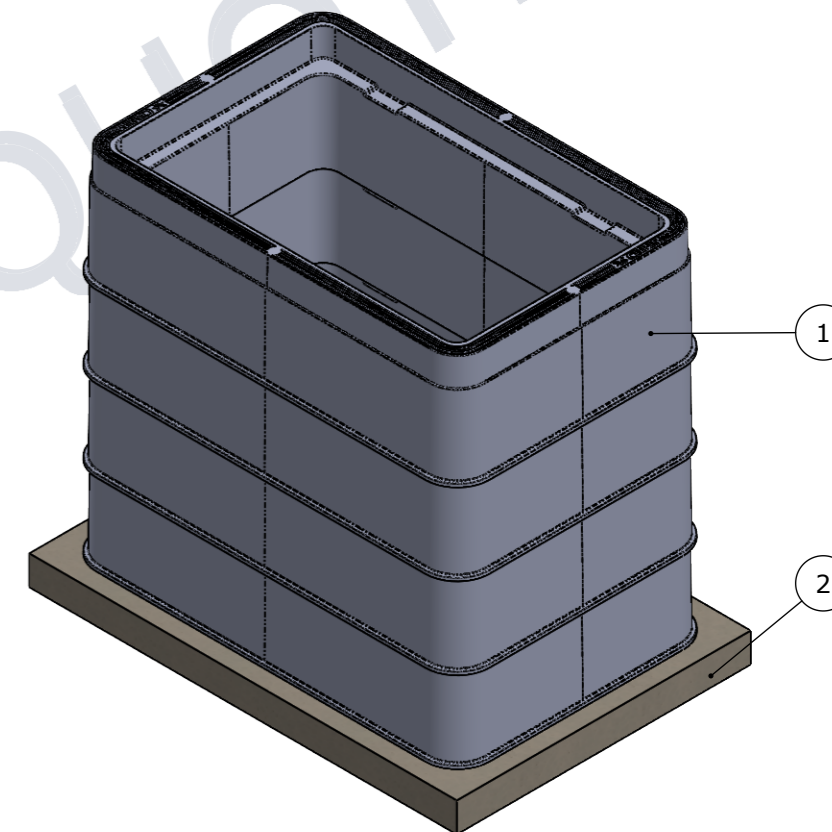
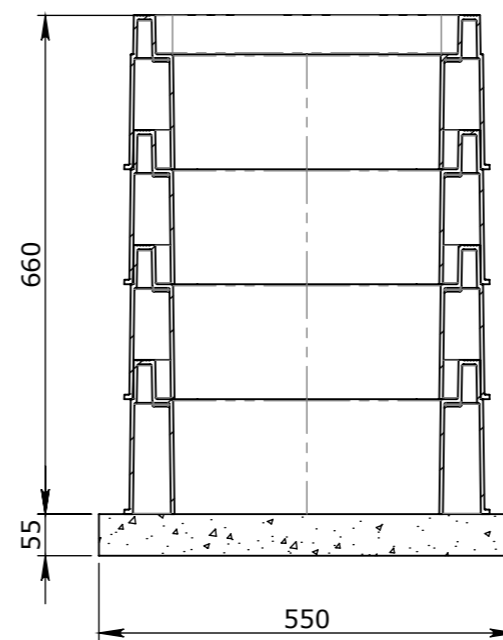
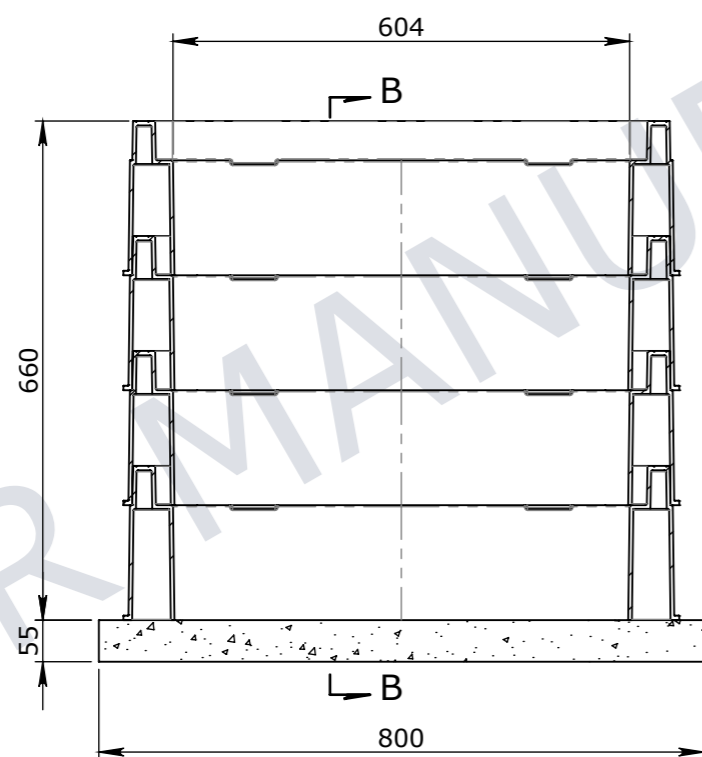
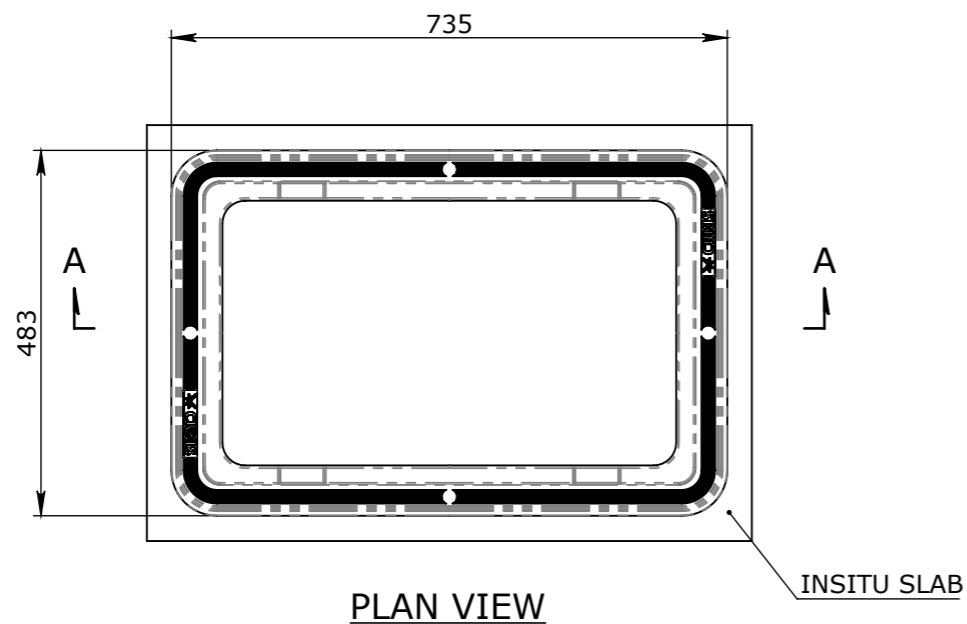

UNCONTROLLED DOCUMENT WHEN PRINTED

TOLERANCE NOTES:

- CONCRETE TOLERANCES TO BE IN CONJUNCTION / ACCORDANCE WITH AS3600 - CONCRETE STRUCTURES
- WHEN A BROOM FINISH IS REQUIRED THE GENERAL TOLERANCE SUPERCEDES THE FLATNESS TOLERANCE
- WALL THICKNESS - DIMENSION AS NOTED IS MINIMUM THICKNESS ONLY
- CONCRETE GRADE - 40MPA UNLESS NOTED OTHERWISE
- DIMENSIONS ARE NOT INCLUSIVE OF SEALANTS OF JOINTS
- SURFACE FINISH - CLASS 4 (AS3610.1)

Rev	DESCRIPTION	DATE	BY	APPROVED
3				
2				
1				

GENERAL TOLERANCES		REVISION CONTROL	
NOMINAL:	UP TO 1000mm	1M AND ABOVE	FLATNESS: (NOT INCLUDING BROOME FINISH)
TOLERANCE:	±5mm	1mm IN 200mm UP TO A MAXIMUM OF 20mm	±4mm PER 1M WIDTH MAX IN 1M LENGTH

CHK / APPR: Revee Lein	DATE: 7/12/2023
DRAFTED BY: M. Orozco	
RPEQ DOCUMENT #:	
WEIGHT:	78.2Kg
MATERIAL:	<NOT SPECIFIED>
IRF REF:	

Infrastructure Products Australia
A CRH COMPANY

HEAD OFFICE:
1 REEVES COURT
BREAKWATER, VIC 3219
1800 065 356

ENGINEERING & DEVELOPMENT:
91 STRADBROKE STREET
HEATHWOOD, QLD 4110
(07) 3714 0444

DRAFTED DATE:	6/12/2023
DRAFTED BY:	TDESILVA
DATE LAST SAVED:	7/12/2023
LAST SAVED BY:	ROROZCO
DRAWN TO AS 1100 DO NOT SCALE FROM SHEET	

PART/PRODUCT #	50201807	QUOTE #		ORDER #	
REINFORCEMENT COMPUTATION		PIT #		ITEM TYPE	
CLIENT	INFRASTRUCTURE PRODUCTS AUSTRALIA				
PROJECT DESC	HS5 RING AND UTILITY BASE MIX KIT				
DRAWING NAME					
DRAWING #	50201807	PAGE	1 / 1	SHEET SIZE	A3
SCALE	1:10	REV.	0		