

BOM:50201232

ITEM #	QTY.	PART #	DESCRIPTION	MATERIAL	WEIGHT
1	1	50201232	MONOBOX™ RAIL ROUND DIA1050X1200	LLDPE	35

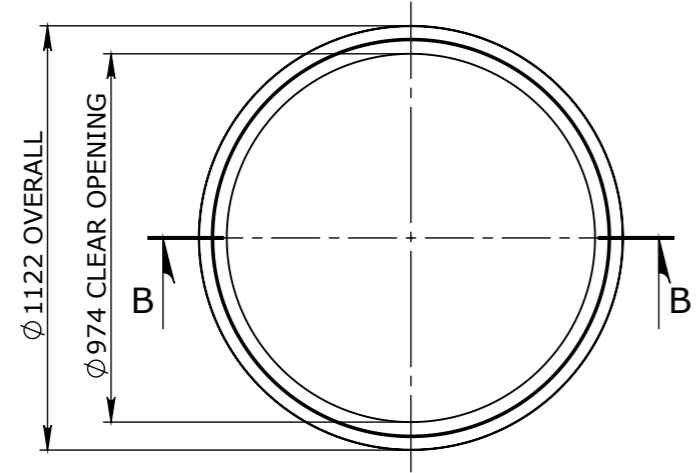

PLAN VIEW

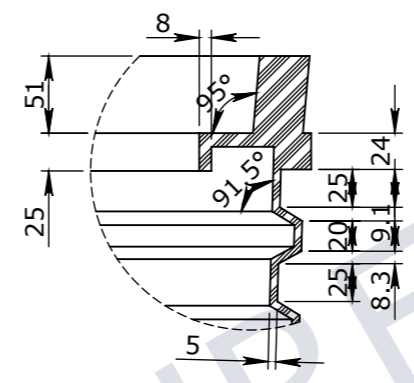

SCALE 1:5
DETAIL D

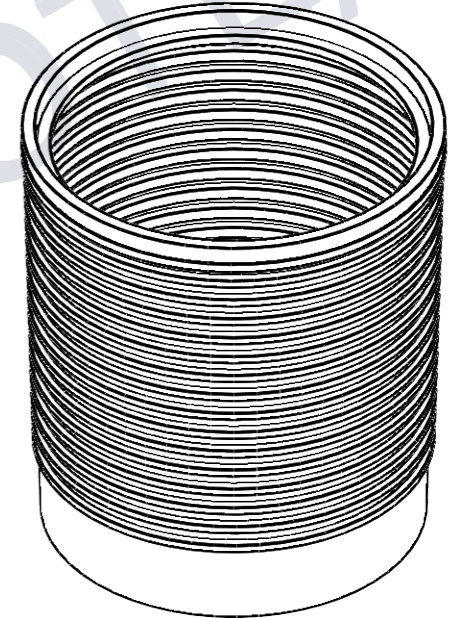

ISOMETRIC VIEW

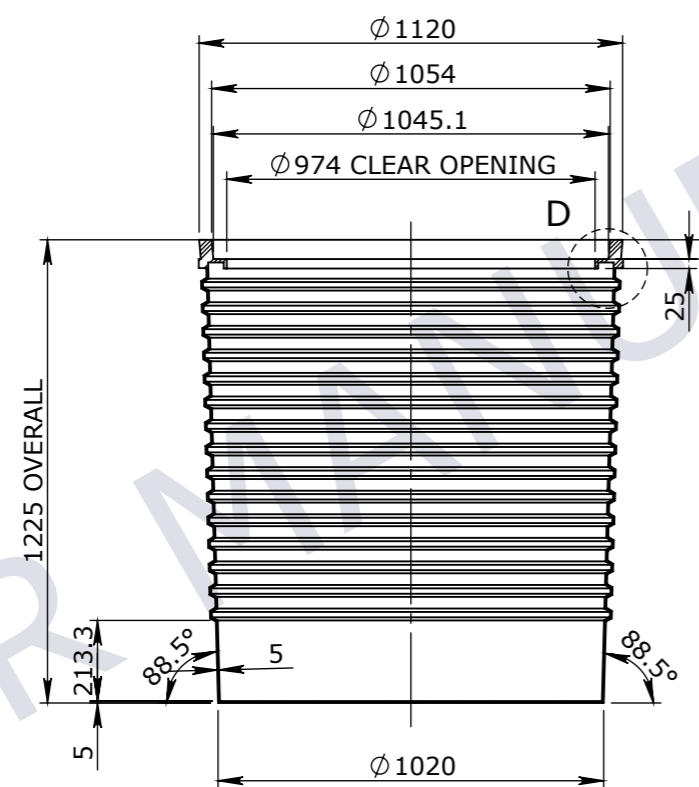

SECTION B-B

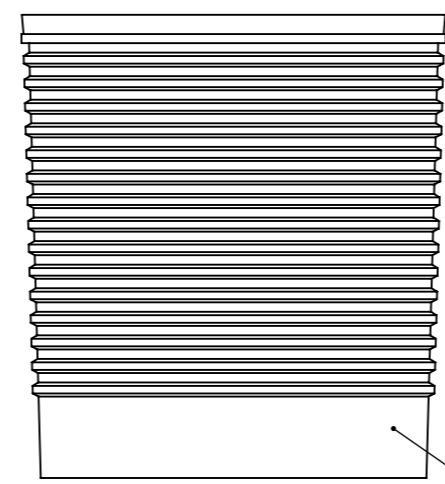

5mm THICKNESS

UNCONTROLLED DOCUMENT WHEN PRINTED

- MATERIAL SPECIFICATIONS UNO SECTIONS & FLATS - AS 3679 - GR 300+ PLATES AS 3678 - GR 250 SHS AS 1163 - GR 350
- WELDING TO COMPLY TO AS 1554.1 UNO

GENERAL TOLERANCES				
NOMINAL SIZE	UP TO 150	ABOVE 150 UP TO 500	ABOVE 500	ANGULAR $\angle X.X \pm 0^\circ 30'$
TOL	± 1.0	± 2.0	± 5.0	$\angle X \pm 1^\circ$

TOLERANCES - FABRICATION		
LINEAR X.XX ± 0.02	FACES SQUARE $\perp 0.05/100$	ANGULAR $\angle X.X \pm 0^\circ 30'$ DIA. CONC WITHIN $\odot 0.05$ TIR
LINEAR X.X ± 0.1	FACES PARALLEL $\parallel 0.05/100$	ANGULAR $\angle X \pm 1^\circ$ EDGES CHAMFERED 1.0 x 45°
LINEAR X. ± 0.25	FACES FLAT $\nabla 0.05/100$	GENERAL SURFACE FINISH Ra 3.2

REVISION CONTROL			
Rev	DESCRIPTION	DATE:	BY:

CHK / APPR:	LEE, MIA
DATE:	
RPEQ DOCUMENT #:	
WEIGHT:	35Kg
MATERIAL:	LLDTE
SURFACE TREATMENT:	

Infrastructure Products Australia
A CRH COMPANY

HEAD OFFICE: 1 REEVES COURT BREAKWATER, VIC 3219 1800 065 356

ENGINEERING & DEVELOPMENT: 91 STRADBROKE STREET HEATHWOOD, QLD 4110 (07) 3714 0444

PART/PRODUCT #	50201232	QUOTE #		ORDER #	
REINFORCEMENT COMPUTATION		PIT #	50201232	ITEM TYPE	
CLIENT	INFRASTRUCTURE PRODUCTS AUSTRALIA				
PROJECT DESC	CATALOGUE PRODUCTS				
DRAWING NAME	MONOBOX™ RAIL ROUND DIA1050X1200				
DRAWING #	50201232	PAGE	1 / 1	SHEET SIZE	A3
SCALE	1:20	REV.	1		