

CONCRETE NOTE:

1. REFER TO GENERAL TOLERANCES UNO
2. GRADE OF CONCRETE - 50MPA COMPLIES WITH AS1379:2007
3. ALL LIFTING POINTS TO BE USED WHEN LIFTING
4. MINIMUM STRENGTH OF CONCRETE SHALL BE 25MPA AT THE TIME OF LIFTING
5. REFER TO IPA STORMWATER PITS INSTALLATION GUIDE FOR INSTALLATION DETAILS
6. REFER TO ANCON LIFTING ARRANGEMENT PLAN
7. KERB UNITS COMPLY WITH AS3600:2018
8. GRATE AND FRAME COMPLY WITH AS3996:2019 FOR CLASS D LOAD RATING
9. EXPOSURE CLASSIFICATIONS - B2 AS PER AS 3600:2018 DESIGN LIFE 50 YEARS AS PER AS3600:2018
10. MINIMUM COVER TO REINFORCEMENT - 25mm

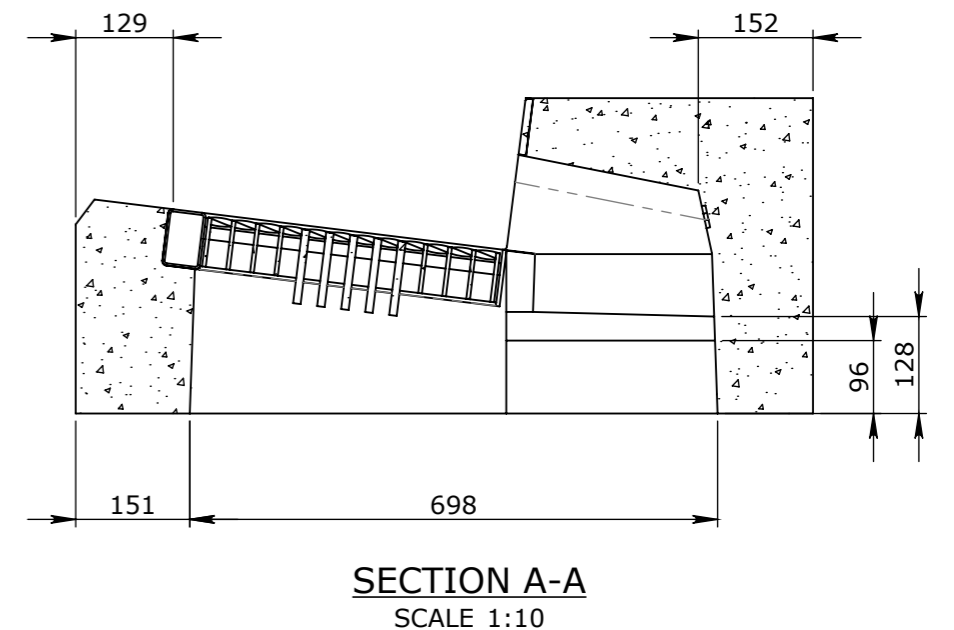
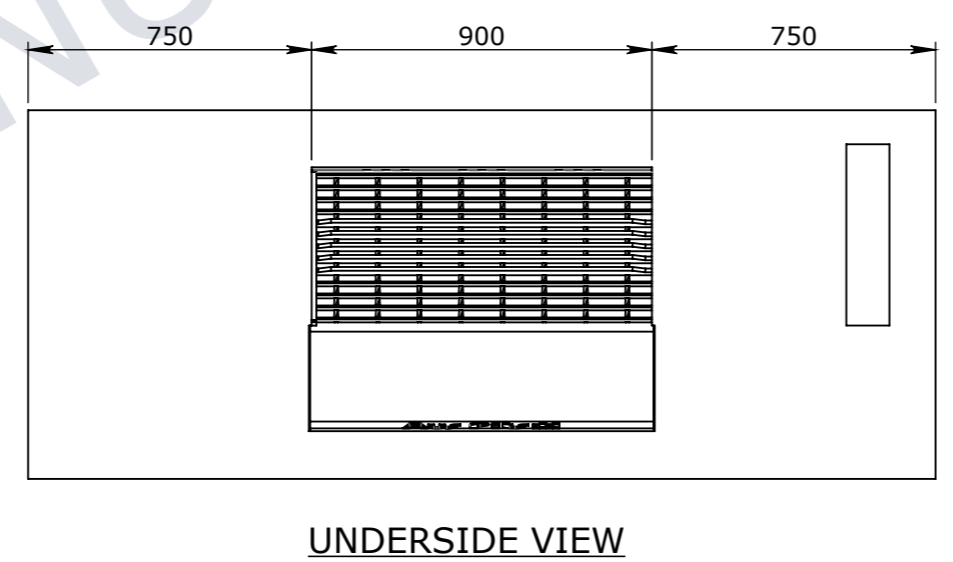
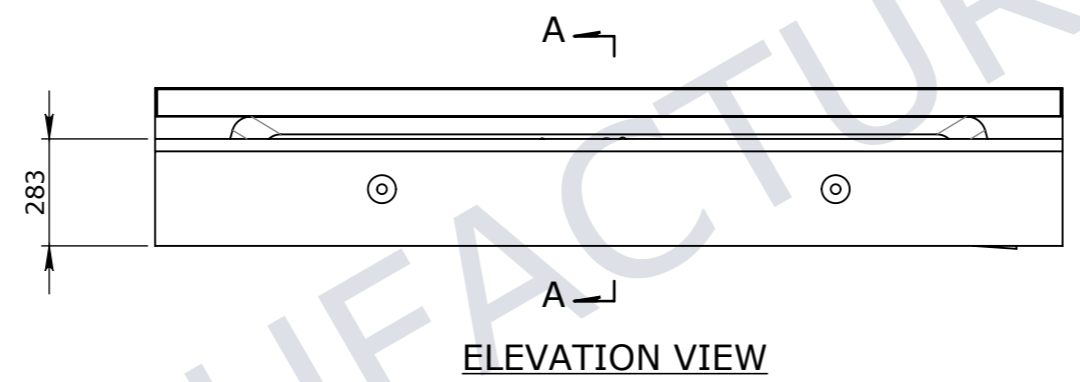
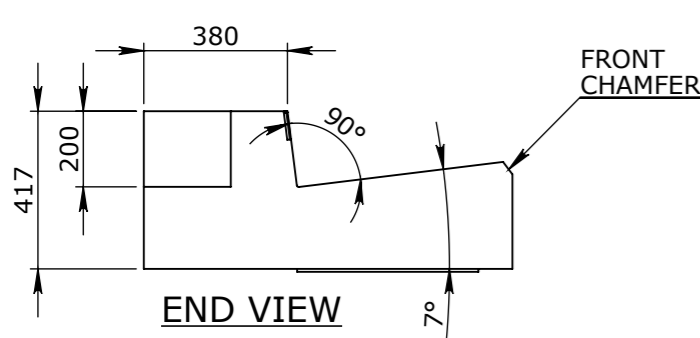
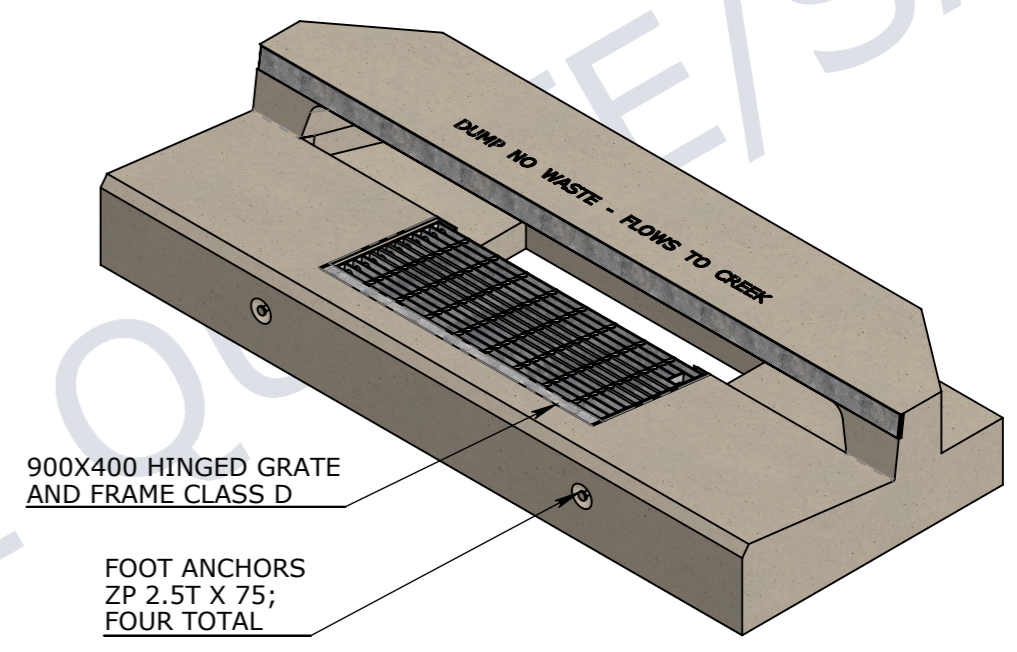
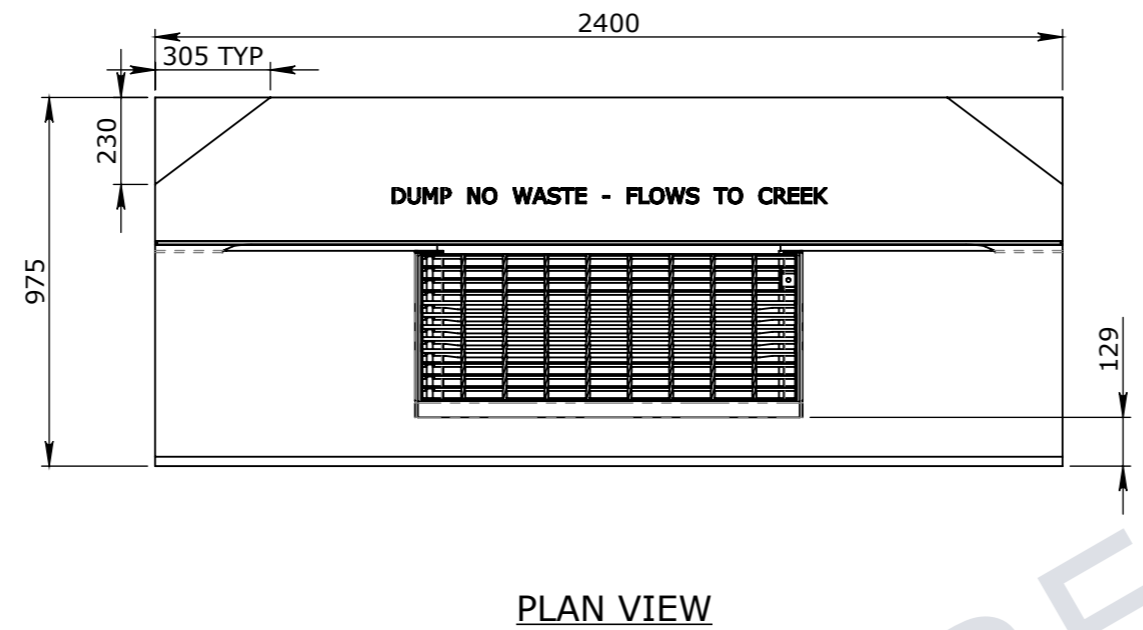

UNCONTROLLED DOCUMENT WHEN PRINTED

TOLERANCE NOTES:

1. CONCRETE TOLERANCES TO BE IN CONJUNCTION / ACCORDANCE WITH AS3600 - CONCRETE STRUCTURES
2. WHEN A BROOME FINISH IS REQUIRED THE GENERAL TOLERANCE SUPERCEDES THE FLATNESS TOLERANCE
3. WALL THICKNESS - DIMENSION AS NOTED IS MINIMUM THICKNESS ONLY
4. CONCRETE GRADE - 40MPA UNLESS NOTED OTHERWISE
5. DIMENSIONS ARE NOT INCLUSIVE OF SEALANTS OF JOINTS
6. SURFACE FINISH - CLASS 4 (AS3610.1)

Rev	DESCRIPTION	DATE	BY	APPROVED
3				
2				
1				

GENERAL TOLERANCES		REVISION CONTROL	
NOMINAL:	UP TO 1000mm	1M AND ABOVE	FLATNESS: (NOT INCLUDING BROOME FINISH)
TOLERANCE:	±5mm	1mm IN 200mm UP TO A MAXIMUM OF 20mm	±4mm PER 1M WIDTH IN 1M LENGTH

CHK / APPR:	PRUSAC, DANIEL
DATE:	
RPEQ DOCUMENT #:	
WEIGHT:	1242.7Kg
MATERIAL:	CONCRETE FIBRE 50MPa
IRF REF:	

CUBIS SYSTEMS
A CRH COMPANY

HEAD OFFICE:
CARNGHAM ROAD
BALLARAT, VIC 3351
(03) 5335 8741

ENGINEERING & DEVELOPMENT:
91 STRADBROKE STREET
HEATHWOOD, QLD 4110
(07) 3714 0444

THE INFORMATION DISCLOSED IN THIS DOCUMENT IS CONFIDENTIAL AND IS NOT WITHOUT THE EXPRESS CONSENT OF CUBIS SYSTEMS

AUSTRALIA TO BE COPIED, REPRODUCED, OR GIVEN TO ANY OTHER PARTY IN ANY FORM AND THAT ALL COPYRIGHT, DESIGNS AND PATENTS VEST IN CUBIS SYSTEMS AUS.

DRAFTED DATE:	30/05/2023
DRAFTED BY:	DPRUSAC
DATE LAST SAVED:	20/06/2023
LAST SAVED BY:	DPRUSAC

PART/PRODUCT #	50207593	QUOTE #		ORDER #	
REINFORCEMENT COMPUTATION		PIT #		ITEM TYPE	KERB UNIT
CLIENT	COUNCILS				
PROJECT DESC	COUNCIL SLIMLINE KERB UNIT				
DRAWING NAME	KERB UNIT INTAKE COUNCIL SLIMLINE LIL SAG 2400mm				
DRAWING #	50207593	PAGE	1 / 2	SHEET SIZE	A3
SCALE	1:20	REV.	0		

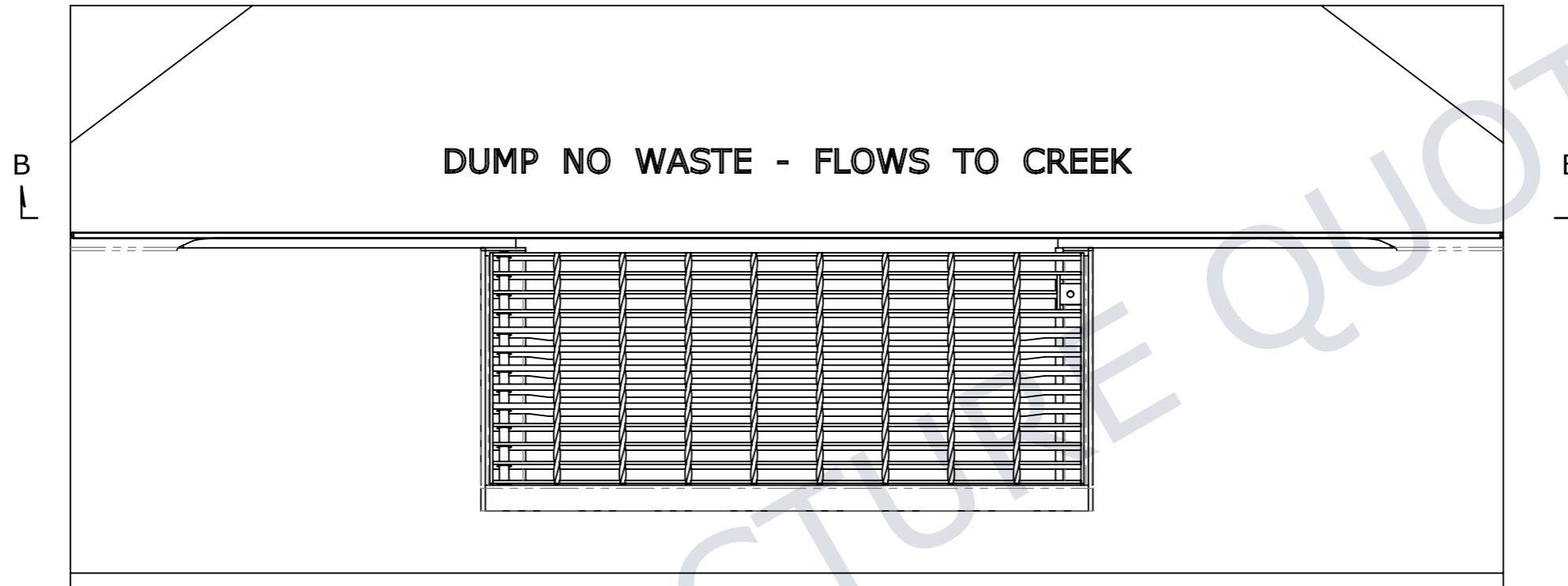

PLAN VIEW

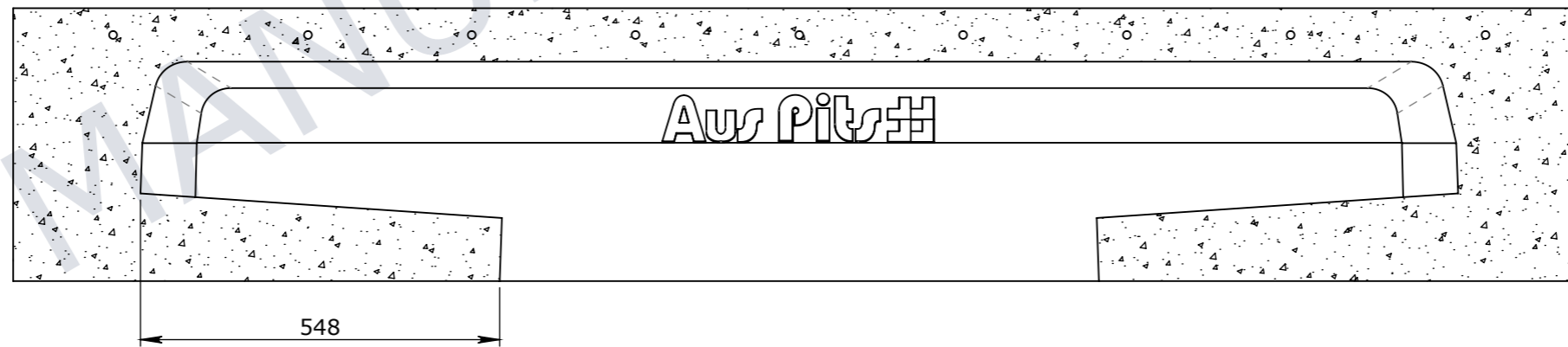

SECTION B-B

FOR MANUFACTURE

	VICTORIA: CARNHAM ROAD BALLARAT, VIC 3351 QLD: 91 STRADBROKE STREET HEATHWOOD, QLD 4110	NAME: KERB UNIT INTAKE COUNCIL SLIMLINE LIL SAG 2400mm		REV 0	
	DRAWN TO AS 1100 DO NOT SCALE FROM SHEET	DRAWING No: 50207593			
	DRAFTED BY: DPRUSAC	DRAFTED DATE: 26/06/2023	PAGE: 2 / 2	SHEET: A3	SCALE UNO: 1:10