

CONCRETE NOTE:

1. REFER TO GENERAL TOLERANCES UNO
2. GRADE OF CONCRETE - 40MPA
3. ALL LIFTING POINTS TO BE USED WHEN LIFTING
4. MINIMUM STRENGTH OF CONCRETE SHALL BE 25MPA AT THE TIME OF LIFTING
5. REFER TO BVCI-INS-C-001 (STD INSTALLATION GUIDE) FOR INSTALLATION DETAILS
6. REFER TO ANCON LIFTING ARRANGEMENT PLAN

BOM:50201726 RISER CONCRETE 200mm TO SUIT 1100x900 PIT

ITEM #	QTY.	PART #	DESCRIPTION	MATERIAL	VOLUME
1	4	50201097	EYE ANCHOR ZP 1.3Tx65mm	MS GR250 GALVANISED	
2	8	50201105	FERRULE ZP M12x50 WITH 65x50 REO	MIXED REINFORCEMENT STEEL	
3	2	50202447	CATCH BOX SUIT SL1 AND SL2	MA GR25 - GALVANISED	
4		50201726	CONCRETE 40MPa	CONCRETE 40MPa	0.19

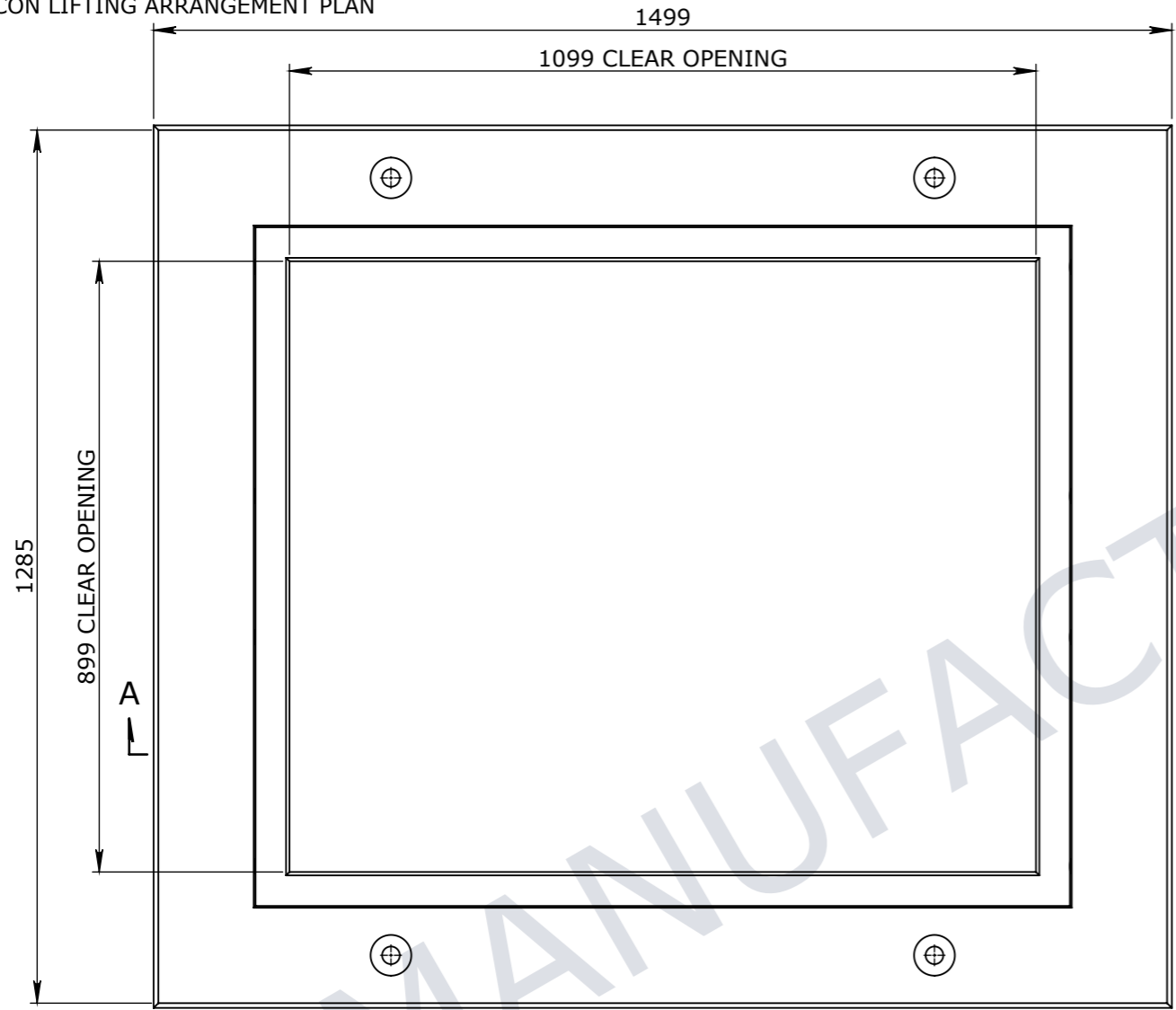

PLAN VIEW

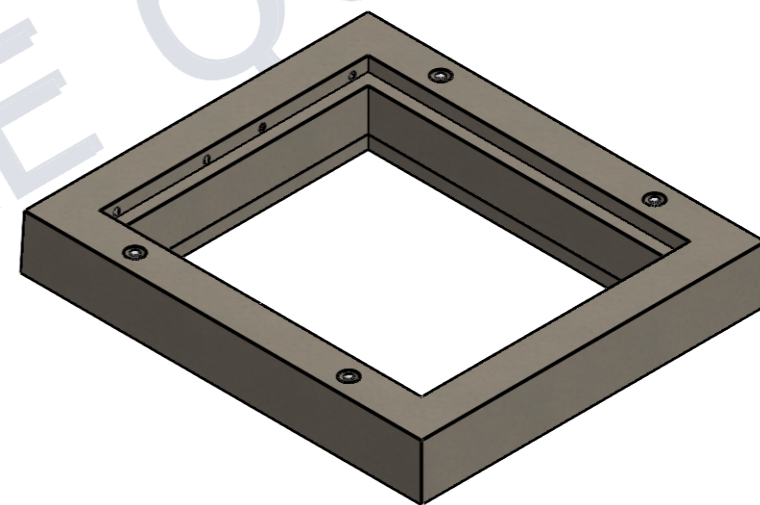

ISOMETRIC VIEW

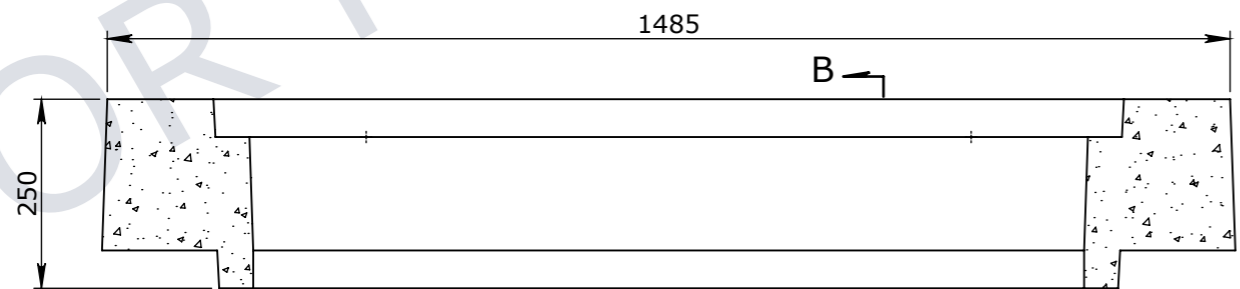

SECTION A-A

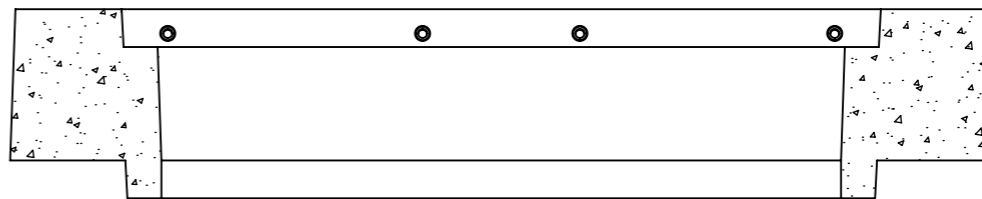

SECTION B-B

UNCONTROLLED DOCUMENT WHEN PRINTED

- TOLERANCE NOTES:**
1. CONCRETE TOLERANCES TO BE IN CONJUNCTION / ACCORDANCE WITH AS3600 - CONCRETE STRUCTURES
 2. WHEN A BROOM FINISH IS REQUIRED THE GENERAL TOLERANCE SUPERCEDES THE FLATNESS TOLERANCE
 3. WALL THICKNESS - DIMENSION AS NOTED IS MINIMUM THICKNESS ONLY
 4. CONCRETE GRADE - 40MPA UNLESS NOTED OTHERWISE
 5. DIMENSIONS ARE NOT INCLUSIVE OF SEALANTS OF JOINTS
 6. SURFACE FINISH - CLASS 4 (AS3610.1)

Rev.	DESCRIPTION	DATE	BY	APPROVED
3				
2				
1				

GENERAL TOLERANCES		REVISION CONTROL	
NOMINAL:	UP TO 1000mm	1M AND ABOVE	FLATNESS: (NOT INCLUDING BROOME FINISH)
TOLERANCE:	±5mm	1mm IN 200mm UP TO A MAXIMUM OF 20mm	±4mm PER 1M WIDTH IN 1M LENGTH

CHK / APPR:	
DATE:	
RREQ DOCUMENT #:	
WEIGHT:	1454.20Kg
MATERIAL:	40MPA CONCRETE
IRF REF:	

Infrastructure Products Australia
A CRH COMPANY

HEAD OFFICE:
1 REEVES COURT
BREAKWATER, VIC 3219
1800 065 356

ENGINEERING & DEVELOPMENT:
91 STRADBROKE STREET
HEATHWOOD, QLD 4110
(07) 3714 0444

DRAFTED DATE:	4/08/2022
DRAFTED BY:	
DATE LAST SAVED:	10/10/2023
LAST SAVED BY:	CABEYSINGH
DRAWN TO AS 1100 DO NOT SCALE FROM SHEET	

PART/PRODUCT #	50201726	QUOTE #		ORDER #	
REINFORCEMENT COMPUTATION		PIT #		ITEM TYPE	
CLIENT	CUBIS SYSTEMS				
PROJECT DESC	RISER CONCRETE 200mm TO SUIT 1100x900 PIT				
DRAWING NAME	RISER CONCRETE 200mm TO SUIT 1100x900 PIT				
DRAWING #	50201726	PAGE	1 / 1	SHEET SIZE	A3
SCALE	1:10	REV.	0		