

CONCRETE NOTE:

1. REFER TO GENERAL TOLERANCES UNO
2. STEEL & FIBRE REINFORCED CONCRETE - 40MPA
3. ALL LIFTING POINTS TO BE USED WHEN LIFTING
4. MINIMUM STRENGTH OF CONCRETE SHALL BE 25MPA AT THE TIME OF LIFTING
5. REFER TO BVCI-INS-C-001 (STD INSTALLATION GUIDE) FOR INSTALLATION DETAILS
6. REFER TO ANCON LIFTING ARRANGEMENT PLAN

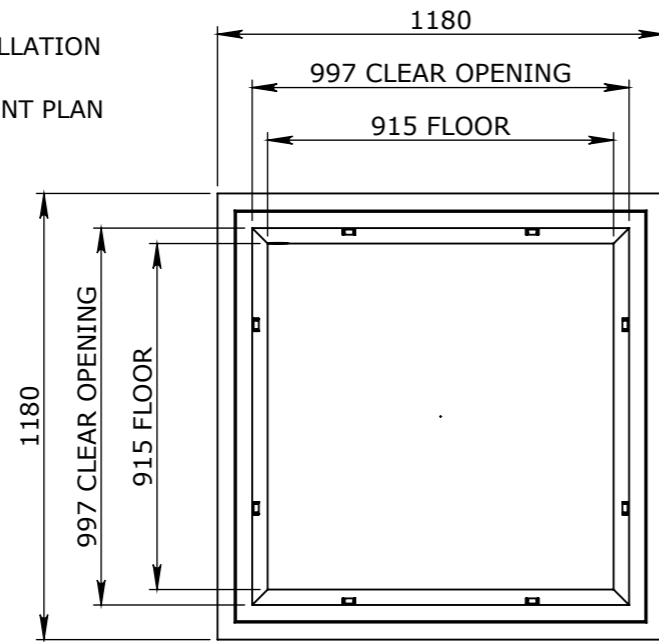

PLAN VIEW

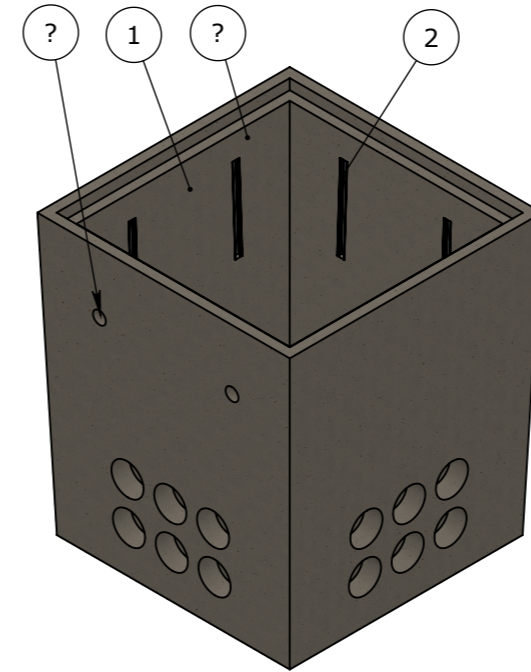

ISOMETRIC VIEW

BILL OF MATERIALS		
ITEM NO.	QTY.	DESCRIPTION
1	1	CAST PIT
2	8	UNISTRUT - P3300

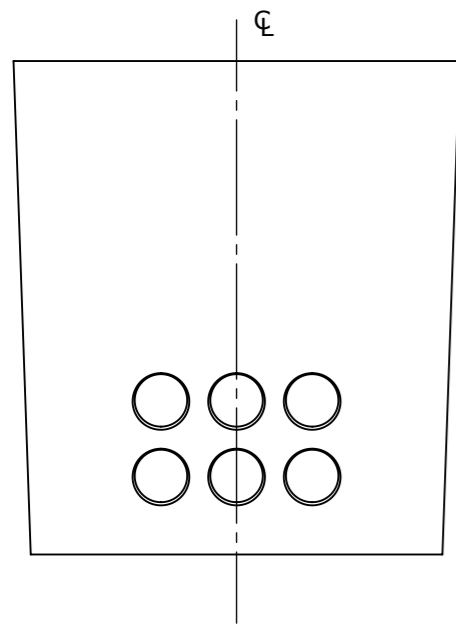
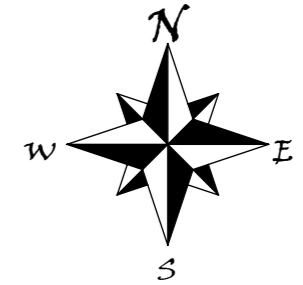

WEST FACE

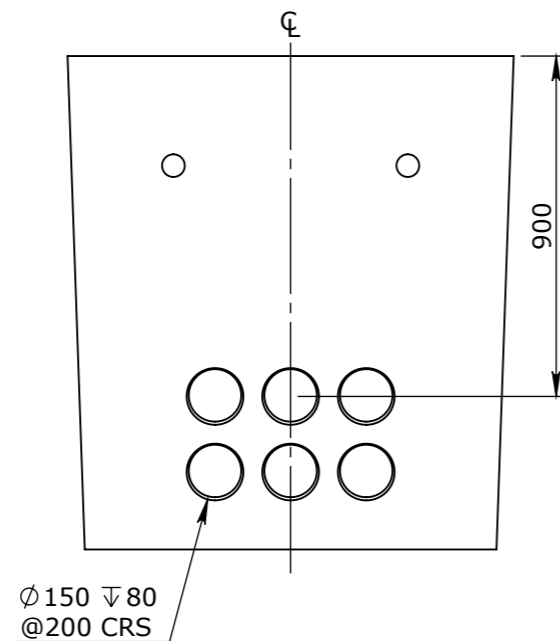

SOUTH FACE

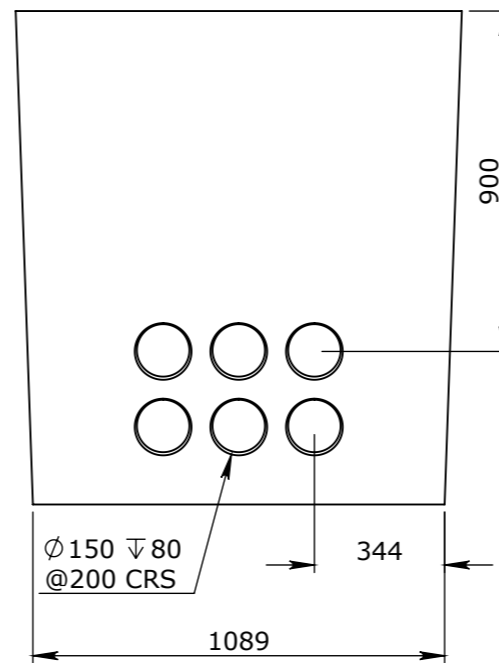

EAST FACE

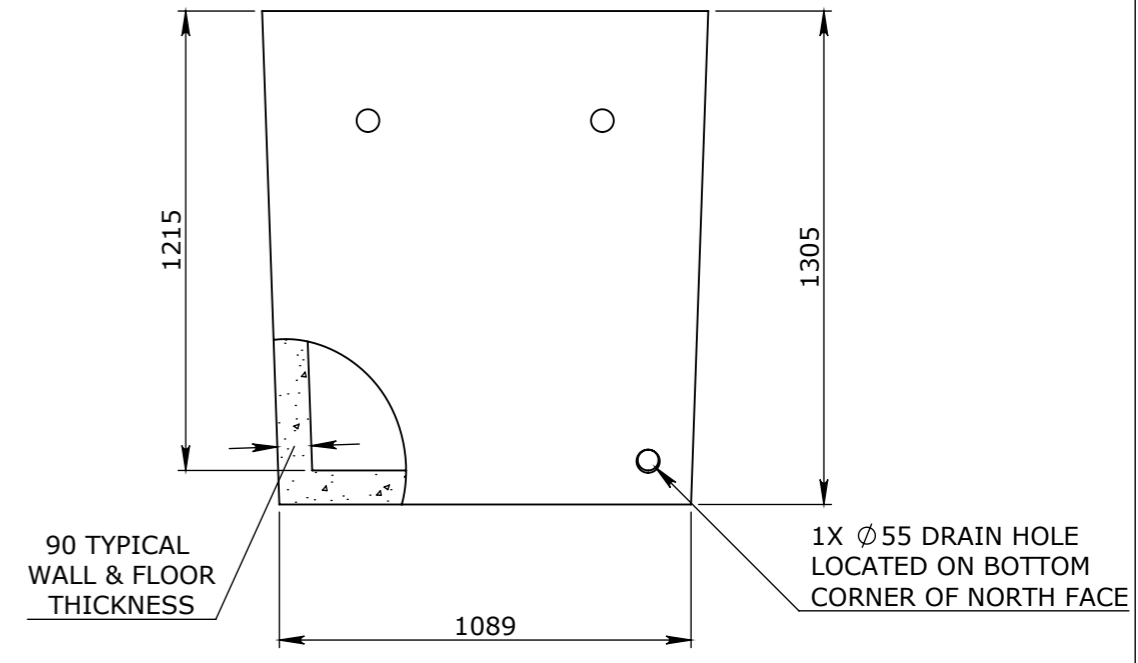

NORTH FACE

- TOLERANCE NOTES:**
1. CONCRETE TOLERANCES TO BE IN CONJUNCTION / ACCORDANCE WITH AS3600 - CONCRETE STRUCTURES
 2. WHEN A BROOME FINISH IS REQUIRED THE GENERAL TOLERANCE SUPERCEEDS THE FLATNESS TOLERANCE
 3. WALL THICKNESS - DIMENSION AS NOTED IS MINIMUM THICKNESS ONLY
 4. CONCRETE GRADE - 40MPA UNLESS NOTED OTHERWISE
 5. DIMENSIONS ARE NOT INCLUSIVE OF SEALANTS OF JOINTS
 6. SURFACE FINISH - CLASS 4 (AS3610.1)

Rev	DESCRIPTION	DATE	BY	APPROVED
3	REVISION UPDATED	24/09/18	CA	
2	NOTES UPDATED	24/09/18	CA	
1	UPDATED LOCATION OF DRAIN HOLE TO BOTTOM CORNER OF NORTH FACE	19/04/18	MO	

GENERAL TOLERANCES		REVISION CONTROL	
NOMINAL:	UP TO 1000mm	1M AND ABOVE	FLATNESS: (NOT INCLUDING BROOME FINISH)
TOLERANCE:	±5mm	1mm IN 200mm UP TO A MAXIMUM OF 20mm	±4mm PER 1M WIDTH IN 1M LENGTH

CHK / APPR:	CA
DATE:	02/05/2018
RPEQ DOCUMENT #:	
WEIGHT:	1302.33Kg
MATERIAL:	CONCRETE 40MPa

HEAD OFFICE:
CARNHAM ROAD
BALLARAT, VIC 3351
(03) 5335 8741

ENGINEERING & DEVELOPMENT:
2 STRADBROKE STREET
HEATHWOOD, QLD 4110
(07) 3714 0444

THE INFORMATION DISCLOSED IN THIS DOCUMENT IS CONFIDENTIAL AND IS NOT WITHOUT THE EXPRESS CONSENT OF CUBIS SYSTEMS AUSTRALIA TO BE COPIED, REPRODUCED, OR GIVEN TO ANY OTHER PARTY IN ANY FORM AND THAT ALL COPYRIGHT, DESIGNS AND PATENTS VEST IN CUBIS SYSTEMS AUS.

DRAFTED DATE:	20/10/2015
DRAFTED BY:	E.ZWICKER
DATE LAST SAVED:	1/07/2022
LAST SAVED BY:	rpaterno
DRAWN TO AS 1100	DO NOT SCALE FROM SHEET

PROJECT:	BVCI GROUP CONCRETE PRODUCTION CATALOGUE ITEM
NAME:	1000x1000x1200 PIT
DRAWING No:	50201517
PROJECT / CATALOGUE CODE:	524113
PAGE:	1 / 1
SHEET:	A3
SCALE UNO:	1:20
REV	A