

This drawing and all information herein is the property of Aus Pits. It must not be copied, made public or used directly, including manufacture of the product shown herein without written approval. This drawing is loaned subject to these conditions and subject to return on demand.

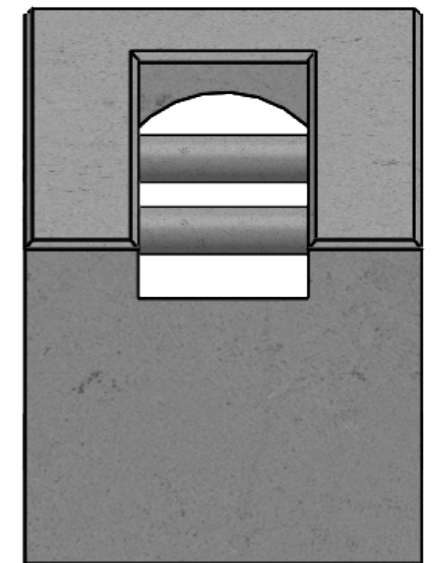
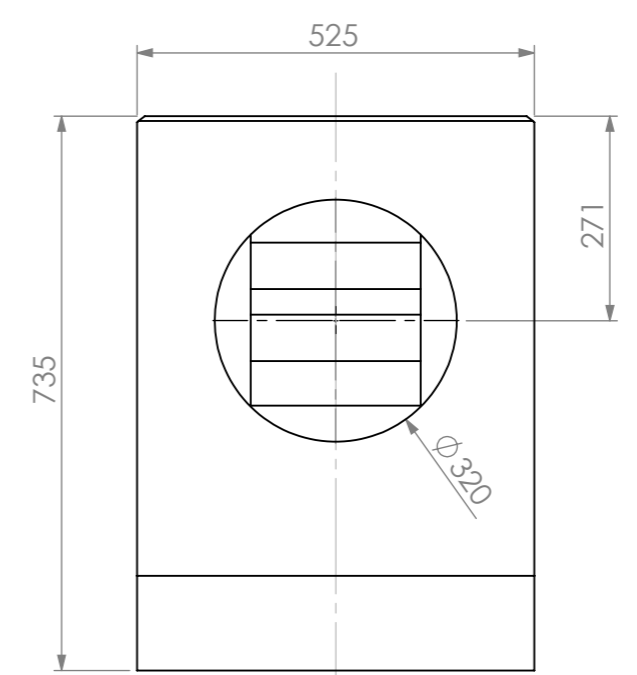
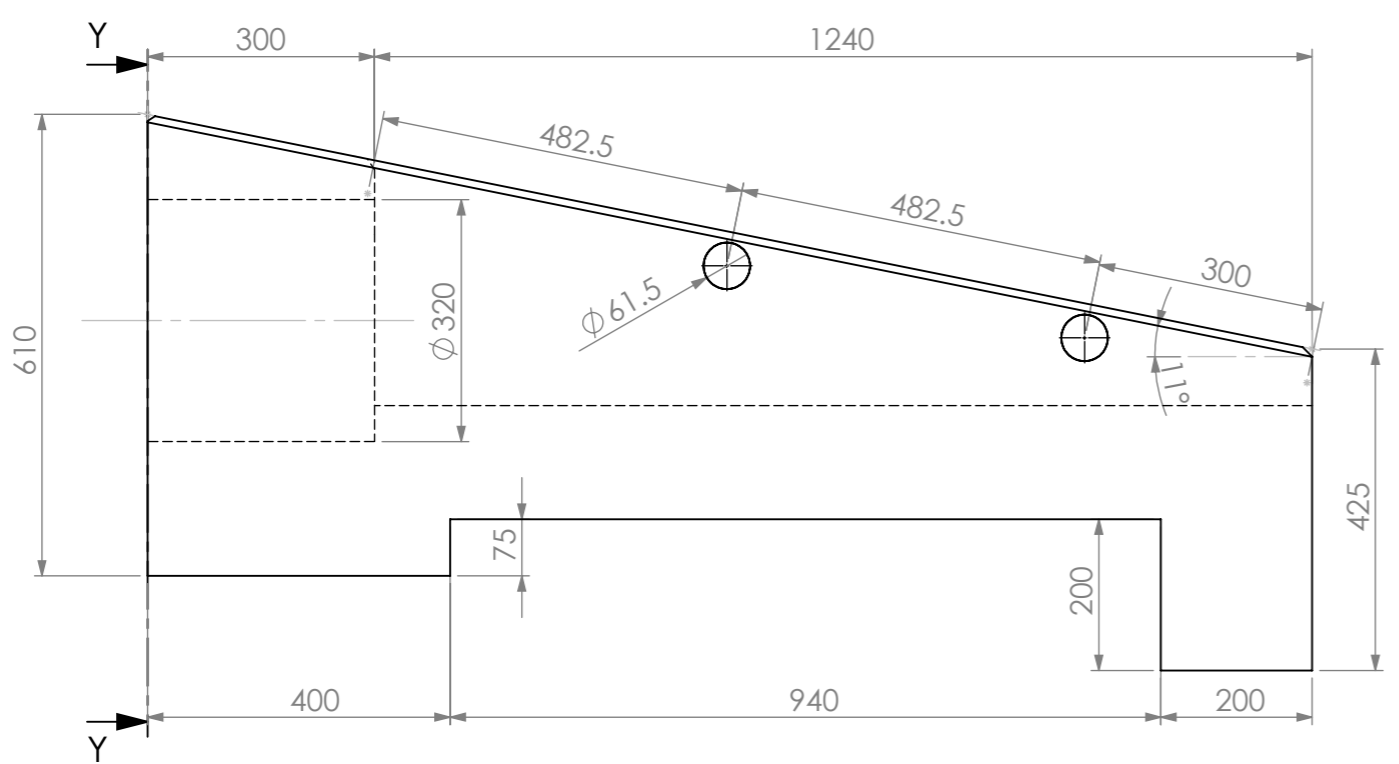
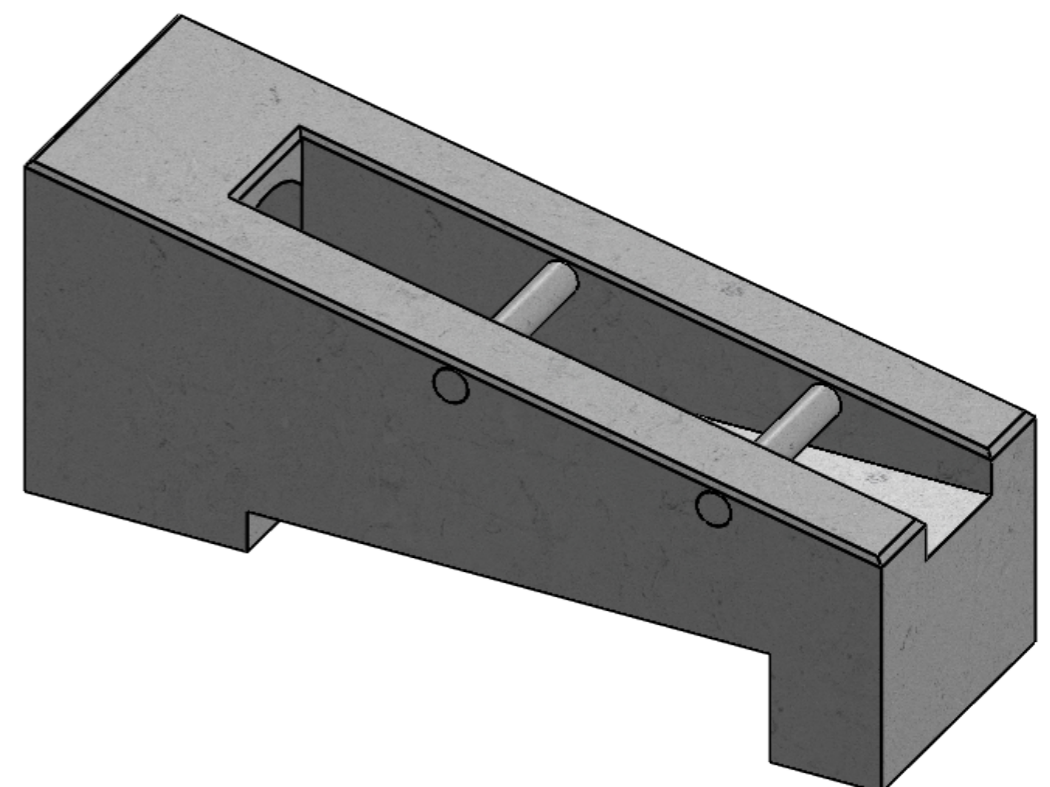
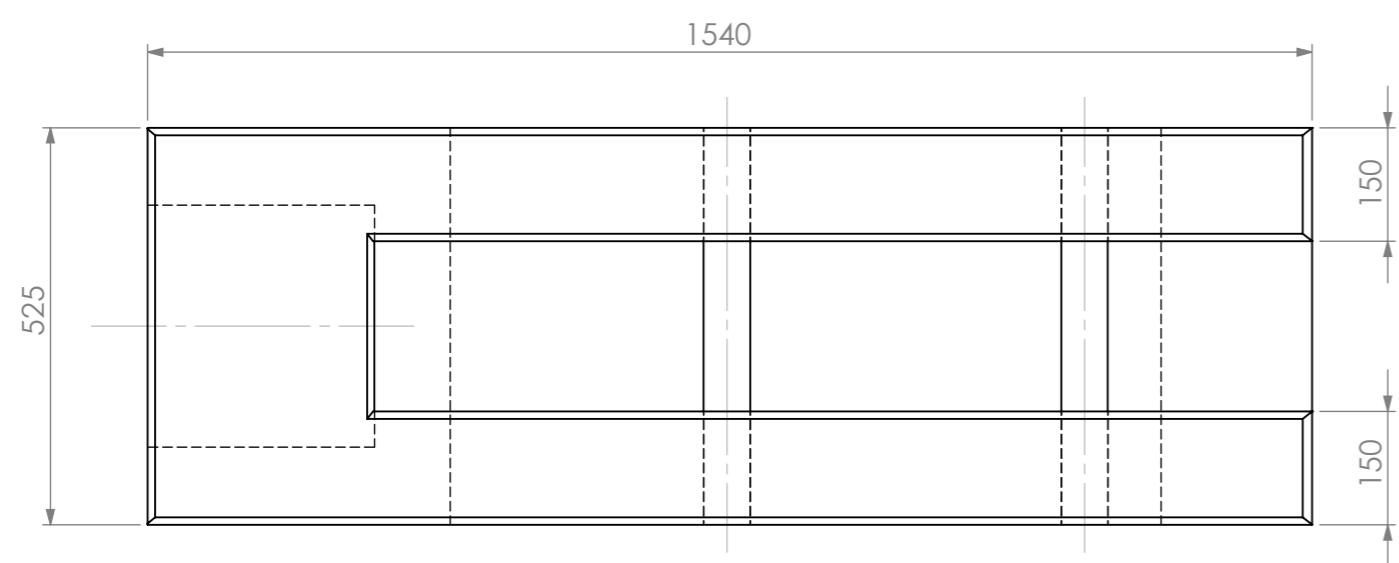

SECTION Y-Y

NOTE
 CONCRETE GRADE-50 (50MPa STRENGTH)
 CONCRETE WEIGHT: 720 KG

REVISION	NO	DATE	DESCRIPTION	BY	CKD.
	01	15-01-19	RELEASED FOR MANUFACTURE	M.L.	T.S.

UNLESS OTHERWISE SPECIFIED:
 DIMENSIONS ARE IN MILLIMETERS
 TOLERANCES:
 LINEAR: ±1.00
 ANGULAR: ±0.50
 DEBUR AND BREAK SHARP EDGES
 DO NOT SCALE DRAWING

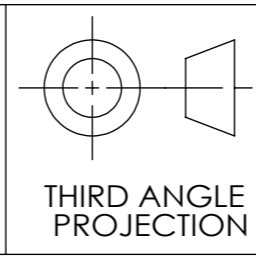

Aus Pits

DRAWN	M.L.
CHK'D	T.S.
DATE	15-01-19

PRECAST DRIVEABLE ENDWALL - 225 DIA			
PART NO.:	PDE225	SCALE:	NTS
DWG NO.	-	SHEET SIZE:	A3
		SHEET 1 OF 1	REVISION
			01