

CONCRETE PRODUCT NOTE:

1. REFER TO GENERAL TOLERANCES UNO
2. GRADE OF CONCRETE - 50MPa (FIBRE)
3. ALL LIFTING POINTS TO BE USED WHEN LIFTING
4. MINIMUM STRENGTH OF CONCRETE SHALL BE 25MPa AT THE TIME OF LIFTING
5. COVER TO REINFORCEMENT TO BE 50mm
6. REFER TO ANCON LIFTING ARRANGEMENT PLAN
7. CONCRETE VOLUME (M³) = [0.09]

BOM:50204308_SLEEPER INTERMEDIATE 1400mm

ITEM #	QTY.	PART #	DESCRIPTION	MATERIAL	VOLUME
1	1	50202614	CONCRETE FIBRE 50MPa	CONCRETE FIBRE 50MPa	0.09
2	2	50201274	FOOT ANCHOR - 1.3Tx65	MS GR-250 GALV	
3	2	50201048	M12x50 FERRULE (ZINC)	ZINC PLATED	

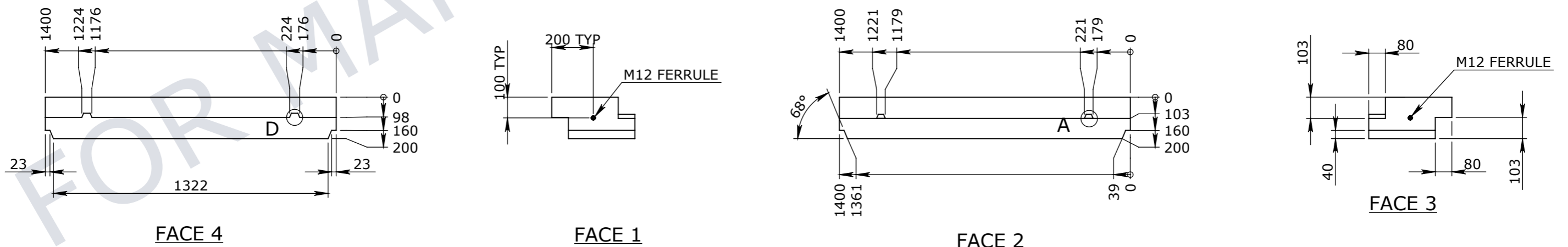
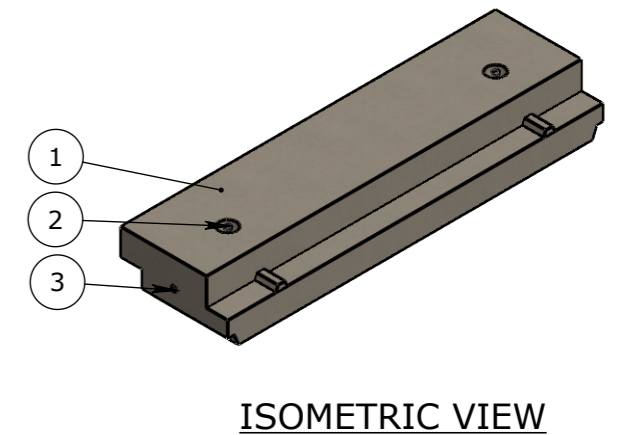
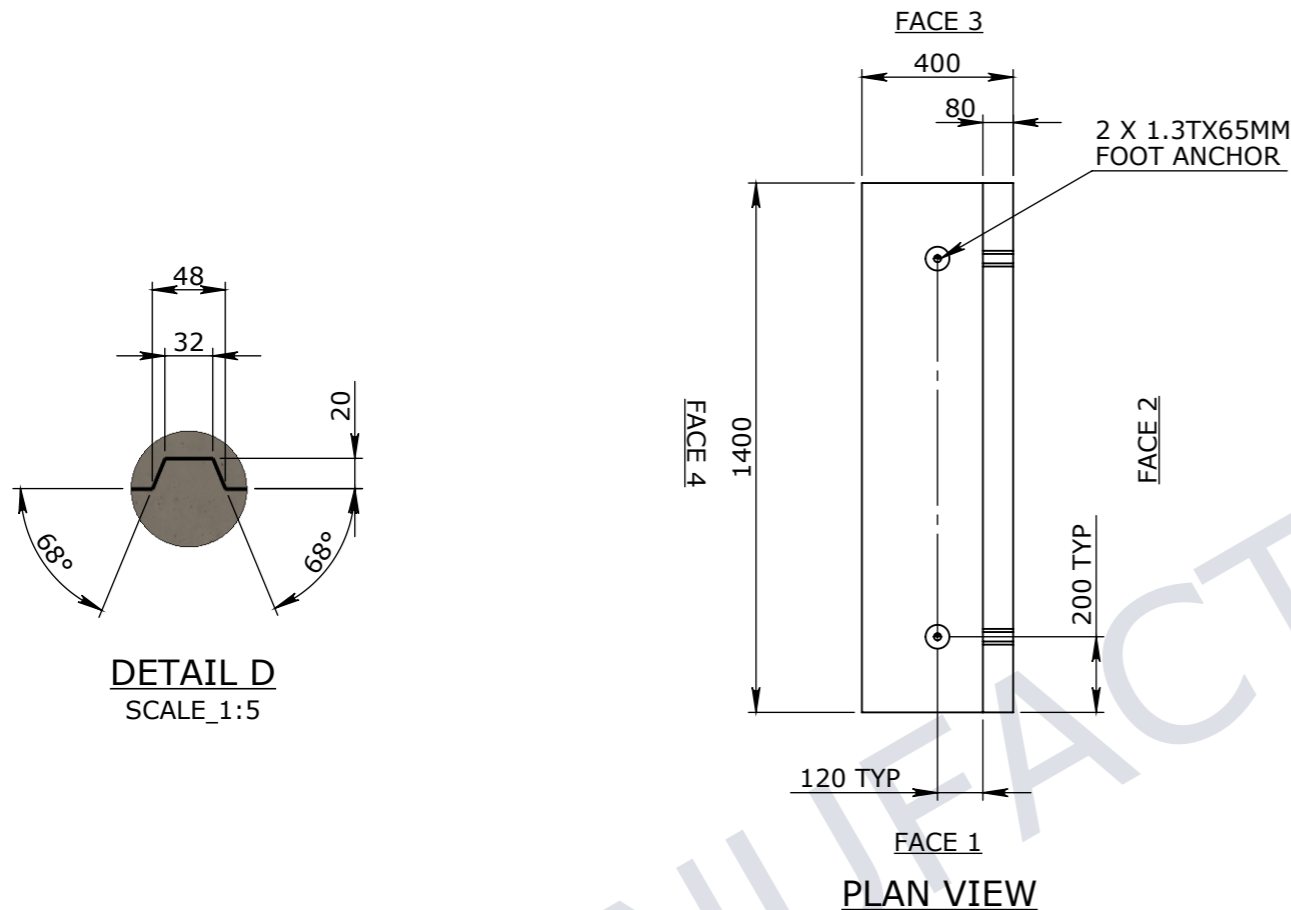

UNCONTROLLED DOCUMENT WHEN PRINTED

- TOLERANCE NOTES:**
1. CONCRETE TOLERANCES TO BE IN CONJUNCTION / ACCORDANCE WITH AS3600 - CONCRETE STRUCTURES
 2. WHEN A BROOME FINISH IS REQUIRED THE GENERAL TOLERANCE SUPERCEEDS THE FLATNESS TOLERANCE
 3. WALL THICKNESS - DIMENSION AS NOTED IS MINIMUM THICKNESS ONLY
 4. CONCRETE GRADE - 40MPa UNLESS NOTED OTHERWISE
 5. DIMENSIONS ARE NOT INCLUSIVE OF SEALANTS OF JOINTS
 6. SURFACE FINISH - CLASS 4 (AS3610.1)

Rev	DESCRIPTION	DATE	BY	APPROVED
3				
2				
1				

GENERAL TOLERANCES		REVISION CONTROL	
NOMINAL:	UP TO 1000mm	1M AND ABOVE	FLATNESS: (NOT INCLUDING BROOME FINISH)
TOLERANCE:	±5mm	1mm IN 200mm UP TO A MAXIMUM OF 20mm	±4mm PER 1M WIDTH IN 1M LENGTH

CHK / APPR:	AC
DATE:	
RPEQ DOCUMENT #:	
WEIGHT:	215.87Kg
MATERIAL:	
IRF REF:	

CUBIS SYSTEMS
A CRH COMPANY

HEAD OFFICE:
CARNINGHAM ROAD
BALLARAT, VIC 3351
(03) 5335 8741

ENGINEERING & DEVELOPMENT:
91 STRADBROKE STREET
HEATHWOOD, QLD 4110
(07) 3714 0444

THE INFORMATION DISCLOSED IN THIS DOCUMENT IS CONFIDENTIAL AND IS NOT WITHOUT THE EXPRESS CONSENT OF CUBIS SYSTEMS

AUSTRALIA TO BE COPIED, REPRODUCED, OR GIVEN TO ANY OTHER PARTY IN ANY FORM AND THAT ALL COPYRIGHT, DESIGNS AND PATENTS VEST IN CUBIS SYSTEMS AUS.

DRAFTED DATE:	24/08/2021
DRAFTED BY:	R.PATERNO
DATE LAST SAVED:	16/11/2021
LAST SAVED BY:	CABEYSINGH
DRAWN TO AS 1100	DO NOT SCALE FROM SHEET

PART/PRODUCT #	50204308	QUOTE #		ORDER #	
REINFORCEMENT COMPUTATION		PIT #		ITEM TYPE	
CLIENT					
PROJECT DESC					
DRAWING NAME	SLEEPER INTERMEDIATE ULTIMA 1400mm				REV.
DRAWING #	50204308	PAGE	1 / 1	SHEET SIZE	A3
		SCALE	1:20		0