

**GENERAL NOTES:**

1. CONCRETE GRADE TO BE 50 MPA MINIMUM
2. DESIGN LIFE OF 50 YEARS  
MINIMUM EXPOSURE CLASSIFICATION - B2  
MINIMUM COVER TO REINFORCEMENT - 40mm
3. DESIGN LIFE OF 100 YEARS  
MINIMUM EXPOSURE CLASSIFICATION - B1  
MINIMUM COVER TO REINFORCEMENT - 40mm
4. DESIGN CAPACITY OF PITS WITH CLASS L REINFORCEMENT HAS BEEN REDUCED 20%
5. ALLOWABLE SOIL BEARING PRESSURE IS 100KPA
6. TOP REBATE TO SUIT RISER SHALL BE ACCORDING TO THE PIT ASSEMBLY DRAWINGS

**BOM:50202828**

ITEM #	QTY.	DESCRIPTION	MATERIAL
1	1	CORBEL WITH REBATE 1200x1350x230	CONCRETE 50MPa
2	4	FOOT ANCHOR 1.3Tx120mm	MS GR-250 GALV

**VIC / 300LA & CLASS D / CORBEL WITH REBATE 1200x1350x230 / UP TO 4m DEPTH**

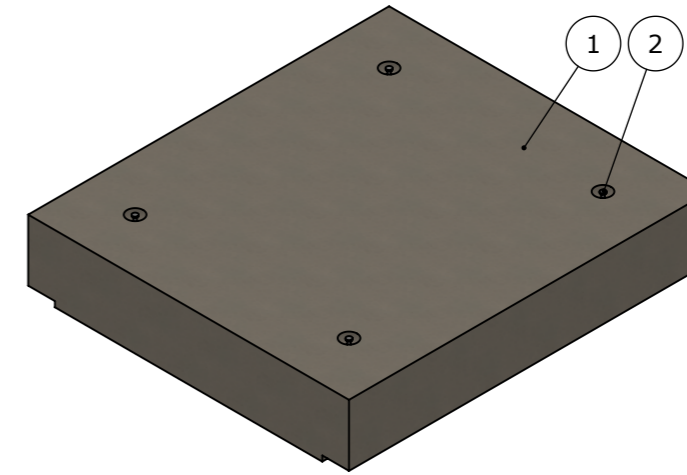
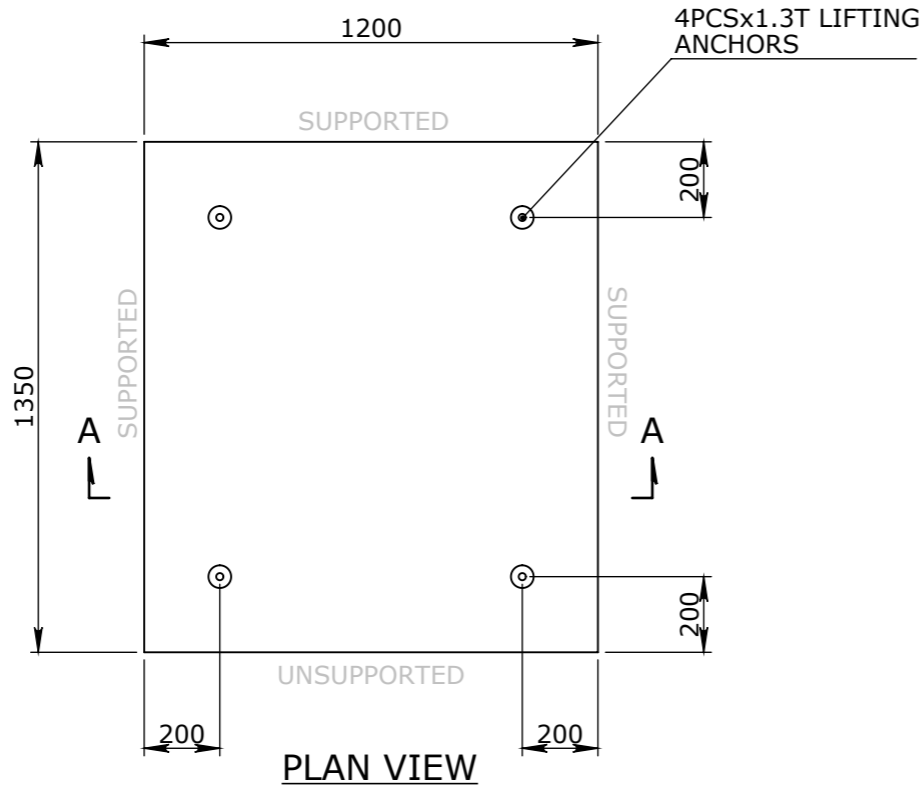

**ISOMETRIC VIEW**

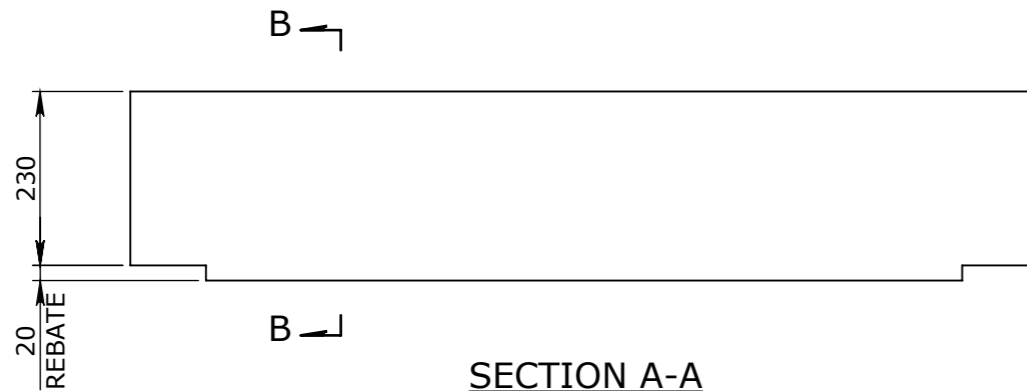

**SECTION A-A**  
SCALE 1:10



**SECTION B-B**  
SCALE 1:10

**ISSUED FOR CONSTRUCTION**

**TOLERANCE NOTES:**

1. CONCRETE TOLERANCES TO BE IN CONJUNCTION / ACCORDANCE WITH AS3600 - CONCRETE STRUCTURES
2. WHEN A BROOME FINISH IS REQUIRED THE GENERAL TOLERANCE SUPERCEEDS THE FLATNESS TOLERANCE
3. WALL THICKNESS - DIMENSION AS NOTED IS MINIMUM THICKNESS ONLY
4. CONCRETE GRADE - 40MPa UNLESS NOTED OTHERWISE
5. DIMENSIONS ARE NOT INCLUSIVE OF SEALANTS OF JOINTS
6. SURFACE FINISH - CLASS 4 (AS3610.1)

Rev.	DESCRIPTION	DATE	BY	APPROVED
3				
2				
1				

GENERAL TOLERANCES		REVISION CONTROL	
NOMINAL:	UP TO 1000mm	1M AND ABOVE	FLATNESS: (NOT INCLUDING BROOME FINISH)
TOLERANCE:	±5mm	1mm IN 200mm UP TO A MAXIMUM OF 20mm	±4mm PER 1M WIDTH IN 1M LENGTH

CHK / APPR:	C
DATE:	
RPEQ DOCUMENT #:	
WEIGHT:	974Kg
MATERIAL:	CONCRETE 50MPa
IRF REF:	

**Aus Pits**

HEAD OFFICE:  
1/1 REEVES COURT, BREAKWATER, VIC 3219  
P: (03) 5222 4526; F: (03) 5222 1914

THE INFORMATION DISCLOSED IN THIS DOCUMENT IS CONFIDENTIAL AND IS NOT WITHOUT THE EXPRESS CONSENT OF AUSPITS AUSTRALIA TO BE COPIED, REPRODUCED, OR GIVEN TO ANY OTHER PARTY IN ANY FORM AND THAT ALL COPYRIGHT, DESIGNS AND PATENTS VEST IN AUSPITS AUSTRALIA

DRAFTED DATE:	30/06/2020
DRAFTED BY:	MLEE
DATE LAST SAVED:	24/08/2020
LAST SAVED BY:	MLEE
DRAWN TO AS 1100 DO NOT SCALE FROM SHEET	

PART/PRODUCT #	QUOTE #	ORDER #
REINFORCEMENT COMPUTATION	PIT #	ITEM TYPE
CLIENT	PROJECT DESC	
	CORBEL (VIC - 300LA & CLASS D)	
ENGINEERING COMPUTATION	DRAWING #	REV.
	50202828	A
PAGE	SHEET SIZE	SCALE
1 / 1	A3	1:20