

FIBRE CONCRETE NOTE:

1. REFER TO GENERAL TOLERANCES UNO
2. STEEL & FIBRE REINFORCED CONCRETE - 50MPa
3. ALL LIFTING POINTS TO BE USED WHEN LIFTING
4. MINIMUM STRENGTH OF CONCRETE SHALL BE 25MPa AT THE TIME OF LIFTING
5. REFER TO CUBIS PRECAST CONCRETE INSTALLATION GUIDE (V.1 2019) FOR INSTALLATION DETAILS
6. REFER TO ANCON LIFTING ARRANGEMENT PLAN

BOM:50202449_

ITEM #	QTY.	PART #	DESCRIPTION	MATERIAL	VOLUME
1	1	50202614	CONCRETE FIBER 50MPa	CONCRETE FIBRE 50MPa	0.2
2	18	50201048	FERRULE ZP M12x50 C/W 10mm HOLE	MS GR250 ZINC	
3	4	50201274	FOOT ANCHOR GALV 1.3Tx65mm	MS GR-250 GALV	

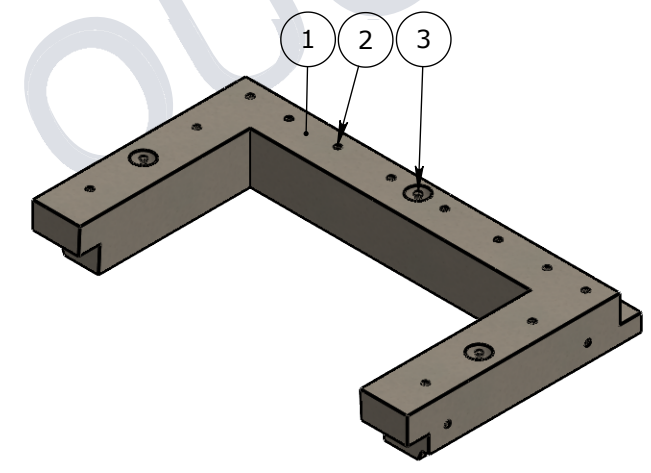
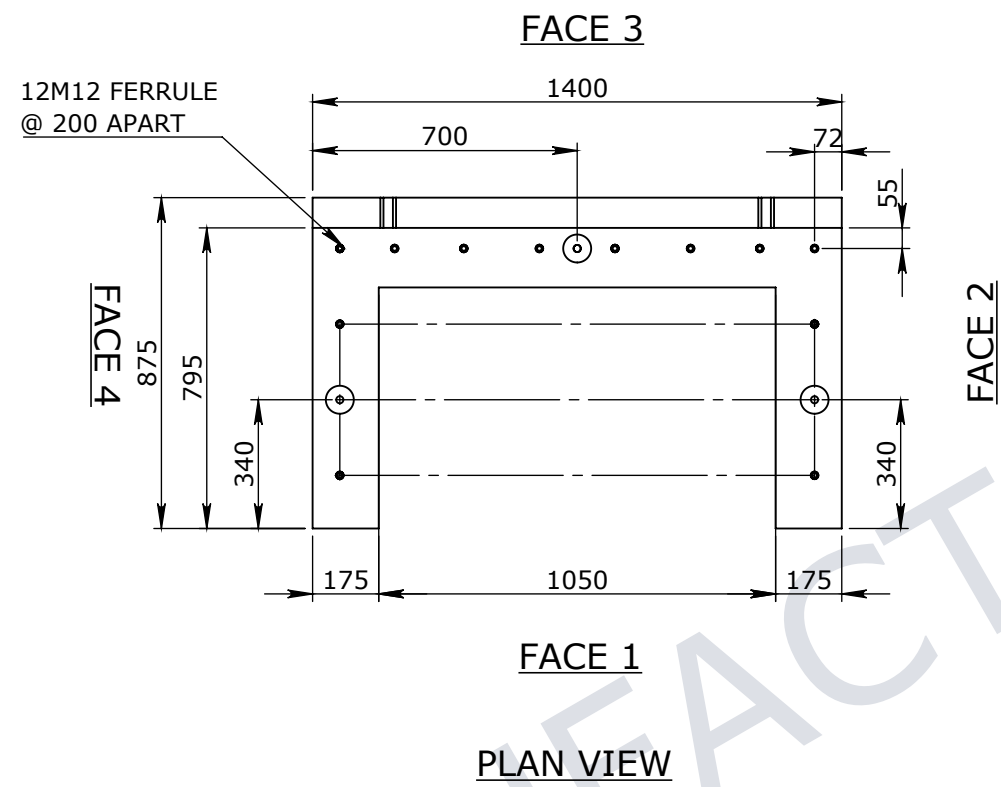

ISOMETRIC VIEW

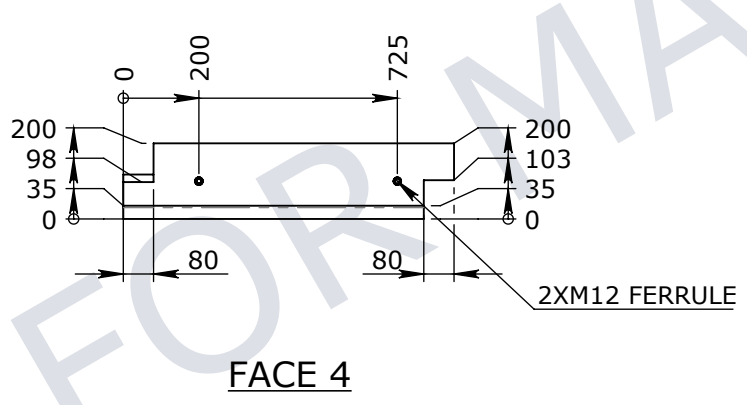

FACE 4

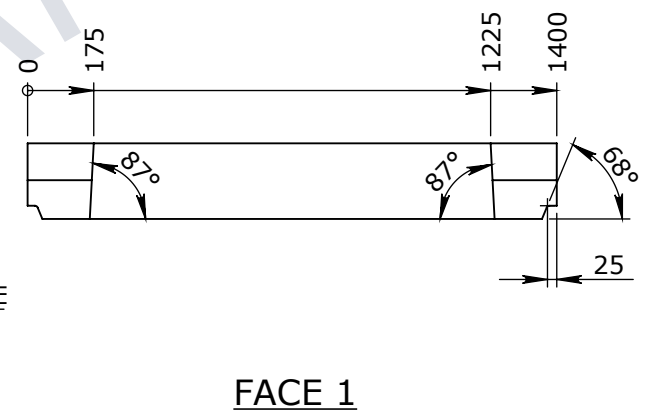

FACE 1

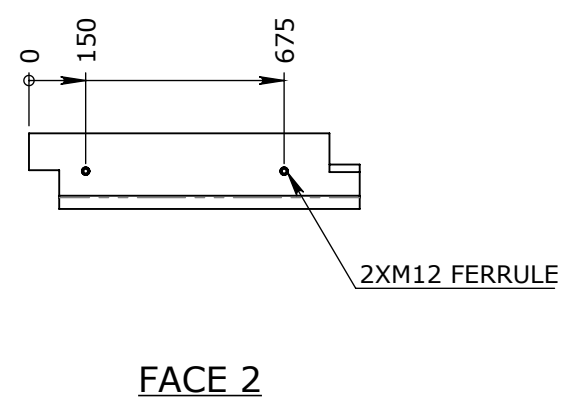

FACE 2

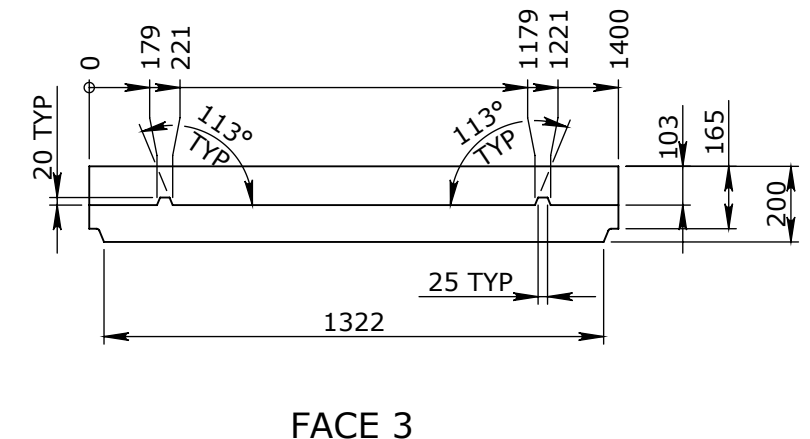

FACE 3

UNCONTROLLED DOCUMENT WHEN PRINTED

TOLERANCE NOTES:

1. CONCRETE TOLERANCES TO BE IN CONJUNCTION / ACCORDANCE WITH AS3600 - CONCRETE STRUCTURES
2. WHEN A BROOME FINISH IS REQUIRED THE GENERAL TOLERANCE SUPERCEEDS THE FLATNESS TOLERANCE
3. WALL THICKNESS - DIMENSION AS NOTED IS MINIMUM THICKNESS ONLY
4. CONCRETE GRADE - 40MPa UNLESS NOTED OTHERWISE
5. DIMENSIONS ARE NOT INCLUSIVE OF SEALANTS OF JOINTS
6. SURFACE FINISH - CLASS 4 (AS3610.1)

Rev	DESCRIPTION	DATE	BY	APPROVED
3				
2				
1				

GENERAL TOLERANCES		REVISION CONTROL	
NOMINAL:	UP TO 1000mm	1M AND ABOVE	FLATNESS: (NOT INCLUDING BROOME FINISH)
TOLERANCE:	±5mm	1mm IN 200mm UP TO A MAXIMUM OF 20mm	±4mm PER 1M WIDTH IN 1M LENGTH

CHK / APPR:	AC
DATE:	
RPEQ DOCUMENT #:	
WEIGHT:	246Kg
MATERIAL:	
IRF REF:	

CUBIS SYSTEMS
A CRH COMPANY

HEAD OFFICE:
CARNINGHAM ROAD
BALLARAT, VIC 3351
(03) 5335 8741

ENGINEERING & DEVELOPMENT:
91 STRADBROKE STREET
HEATHWOOD, QLD 4110
(07) 3714 0444

THE INFORMATION DISCLOSED IN THIS DOCUMENT IS CONFIDENTIAL AND IS NOT WITHOUT THE EXPRESS CONSENT OF CUBIS SYSTEMS

AUSTRALIA TO BE COPIED, REPRODUCED, OR GIVEN TO ANY OTHER PARTY IN ANY FORM AND THAT ALL COPYRIGHT, DESIGNS AND PATENTS VEST IN CUBIS SYSTEMS AUS.

DRAFTED DATE:	23/08/2021	PART/PRODUCT #		QUOTE #		ORDER #	
DRAFTED BY:	D.PRUSAC	REINFORCEMENT COMPUTATION		PIT #		ITEM TYPE	
DATE LAST SAVED:	21/03/2022	CLIENT					
LAST SAVED BY:	NBRADIC	PROJECT DESC					
DRAWING NAME		DRAWING #			PAGE	SHEET SIZE	SCALE
SLEEPER COLLAR TO SUIT 2 PART - PART A		50202449			1 / 1	A3	1:20
REV.							0