

CONCRETE NOTE:

- REFER TO GENERAL TOLERANCES UNO
- GRADE OF FIBRE CONCRETE - 50MPA COMPLIES WITH MRTS273
- ALL LIFTING POINTS TO BE USED WHEN LIFTING
- MINIMUM STRENGTH OF CONCRETE SHALL BE 25MPA AT THE TIME OF LIFTING
- REFER TO PRECAST CONCRETE INSTALLATION GUIDE V.1 2019 FOR INSTALLATION DETAILS
- REFER TO ANCON LIFTING ARRANGEMENT PLAN
- KERB UNITS COMPLY WITH BELOW TMR STANDARDS
 - MRTS72
 - MRTS71
 - MRTS70
 - MRTS78
 - MRTS03
 - MRTS273
- GRATE AND FRAME COMPLY WITH AS3996:2019 FOR CLASS D LOAD RATING
- KERB UNITS COMPLY WITH TMR SD 1443 & 1444 TESTING CRITERIA
- EXPOSURE CLASSIFICATIONS - B2 AS PER AS3600:2017
DESIGN LIFE 50 YEARS AS PER AS3600:2017
MINIMUM COVER TO REINFORCEMENT - 25mm

NOTE:

REINFORCEMENT DESIGN IS NOT SHOWN.
REINFORCEMENT DESIGN COMPLIES WITH TMR SD 1443 & 1444 LOADING REQUIREMENT AND OTHER TMR STANDARDS.

TMR APPROVED
GR/FR 900 X 600
CLASS D HINGE

AUS PITS LOGO
SPRAYED ON LINTEL

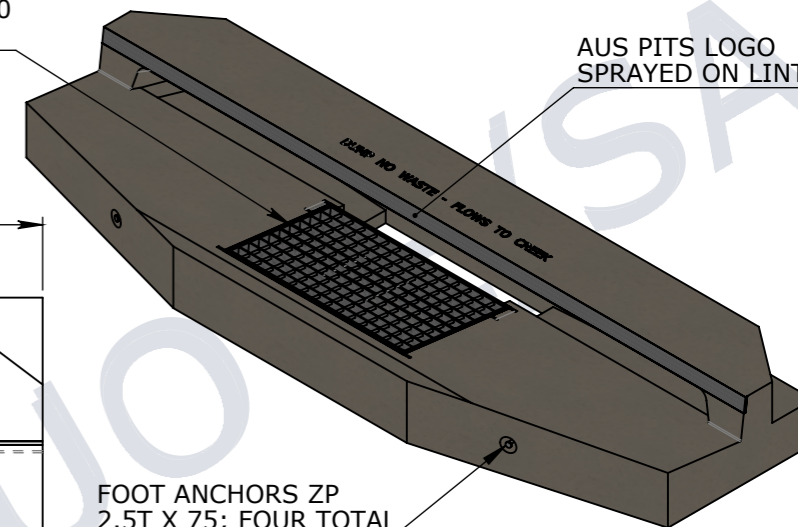

FOOT ANCHORS ZP
2.5T X 75; FOUR TOTAL

ISOMETRIC VIEW

SCALE_1:30

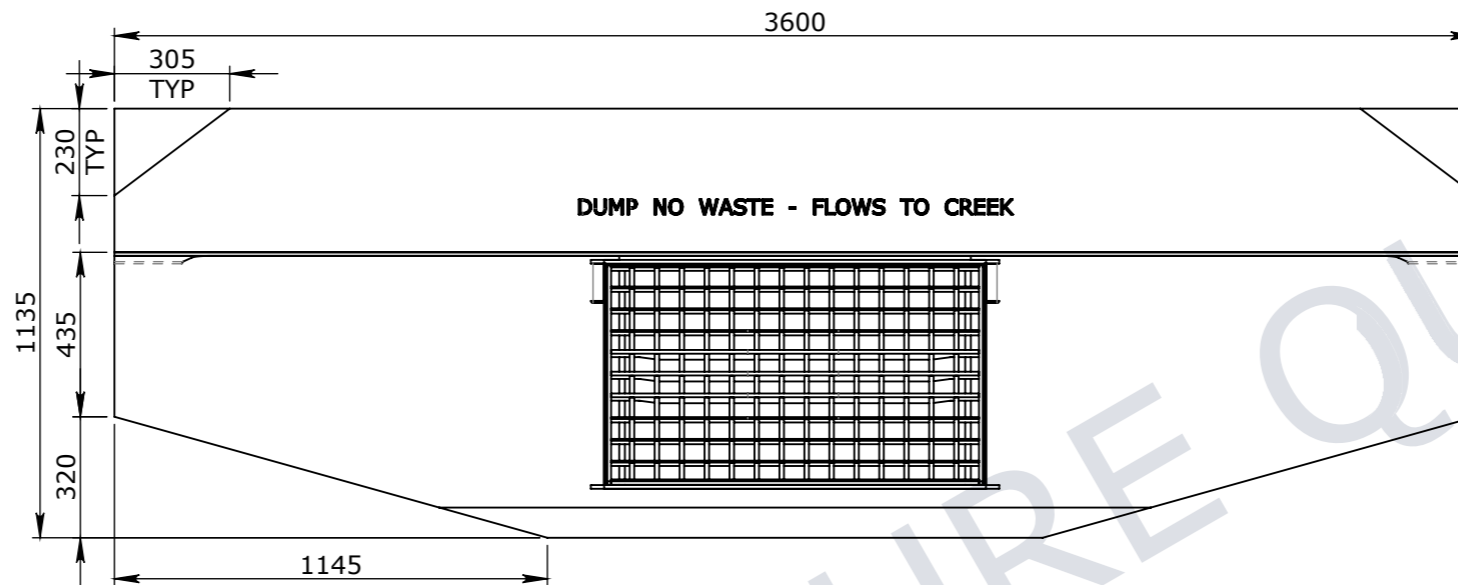

PLAN VIEW

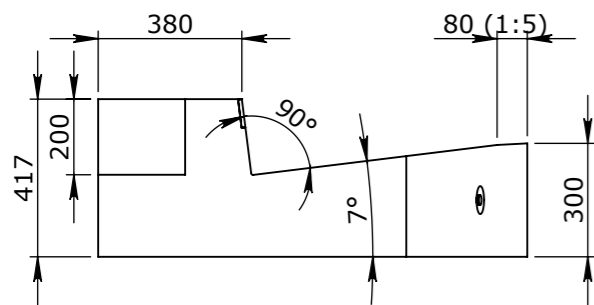

END VIEW



ELEVATION VIEW

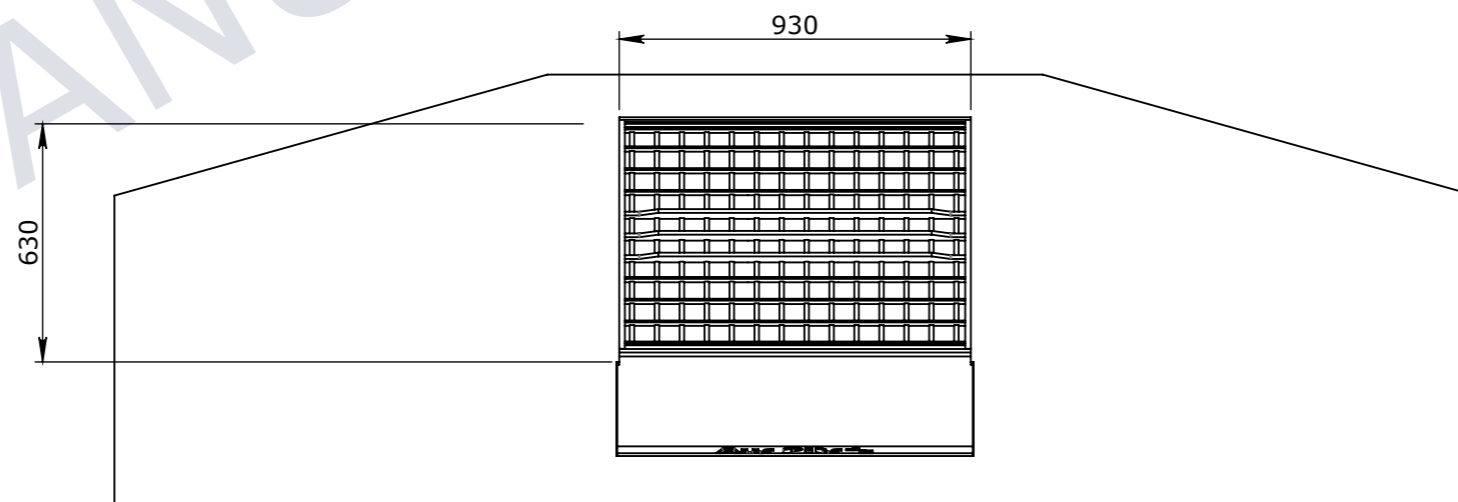

UNDERSIDE VIEW

UNCONTROLLED DOCUMENT WHEN PRINTED

TOLERANCE NOTES:

- CONCRETE TOLERANCES TO BE IN CONJUNCTION / ACCORDANCE WITH AS3600 - CONCRETE STRUCTURES
- WHEN A BROOME FINISH IS REQUIRED THE GENERAL TOLERANCE SUPERCEEDS THE FLATNESS TOLERANCE
- WALL THICKNESS - DIMENSION AS NOTED IS MINIMUM THICKNESS ONLY
- CONCRETE GRADE - 40MPA UNLESS NOTED OTHERWISE
- DIMENSIONS ARE NOT INCLUSIVE OF SEALANTS OF JOINTS
- SURFACE FINISH - CLASS 4 (AS3610.1)

| Rev | DESCRIPTION | DATE | BY | APPROVED |
|-----|-------------|------|----|----------|
| 3 | | | | |
| 2 | | | | |
| 1 | | | | |

| GENERAL TOLERANCES | | REVISION CONTROL | |
|--------------------|--------------|--------------------------------------|---|
| NOMINAL: | UP TO 1000mm | 1M AND ABOVE | FLATNESS: (NOT INCLUDING BROOME FINISH) |
| TOLERANCE: | ±5mm | 1mm IN 200mm UP TO A MAXIMUM OF 20mm | ±4mm PER 1M WIDTH IN 1M LENGTH |

| | |
|------------------|------------|
| CHK / APPR: | Abeyasingh |
| DATE: | Chanaka |
| RPEQ DOCUMENT #: | |
| WEIGHT: | 2031.4Kg |
| MATERIAL: | |
| IRF REF: | |

CUBIS SYSTEMS
A CRH COMPANY

HEAD OFFICE:
CARNINGHAM ROAD
BALLARAT, VIC 3351
(03) 5335 8741

ENGINEERING & DEVELOPMENT:
91 STRADBROKE STREET
HEATHWOOD, QLD 4110
(07) 3714 0444

THE INFORMATION DISCLOSED IN THIS DOCUMENT IS CONFIDENTIAL AND IS NOT WITHOUT THE EXPRESS CONSENT OF CUBIS SYSTEMS

AUSTRALIA TO BE COPIED, REPRODUCED, OR GIVEN TO ANY OTHER PARTY IN ANY FORM AND THAT ALL COPYRIGHT, DESIGNS AND PATENTS VEST IN CUBIS SYSTEMS AUS.

| | |
|------------------|-------------------------|
| DRAFTED DATE: | 28/08/2020 |
| DRAFTED BY: | DPRUSAC |
| DATE LAST SAVED: | 30/03/2022 |
| LAST SAVED BY: | CABEYSINGH |
| DRAWN TO AS 1100 | DO NOT SCALE FROM SHEET |

| | | | | | |
|---------------------------|--|---------|----------|------------|----|
| PART/PRODUCT # | 50207102 | QUOTE # | | ORDER # | |
| REINFORCEMENT COMPUTATION | | PIT # | | ITEM TYPE | |
| CLIENT | DEPARTMENT OF TRANSPORT AND MAIN ROADS | | | | |
| PROJECT DESC | TMR KERB UNITS | | | | |
| DRAWING NAME | KERB UNIT INTAKE TMR KIL SAG 3600mm | | | | |
| DRAWING # | 50207102 | PAGE | 1 / 2 | SHEET SIZE | A3 |
| SCALE | 1:20 | REV. | A | | |

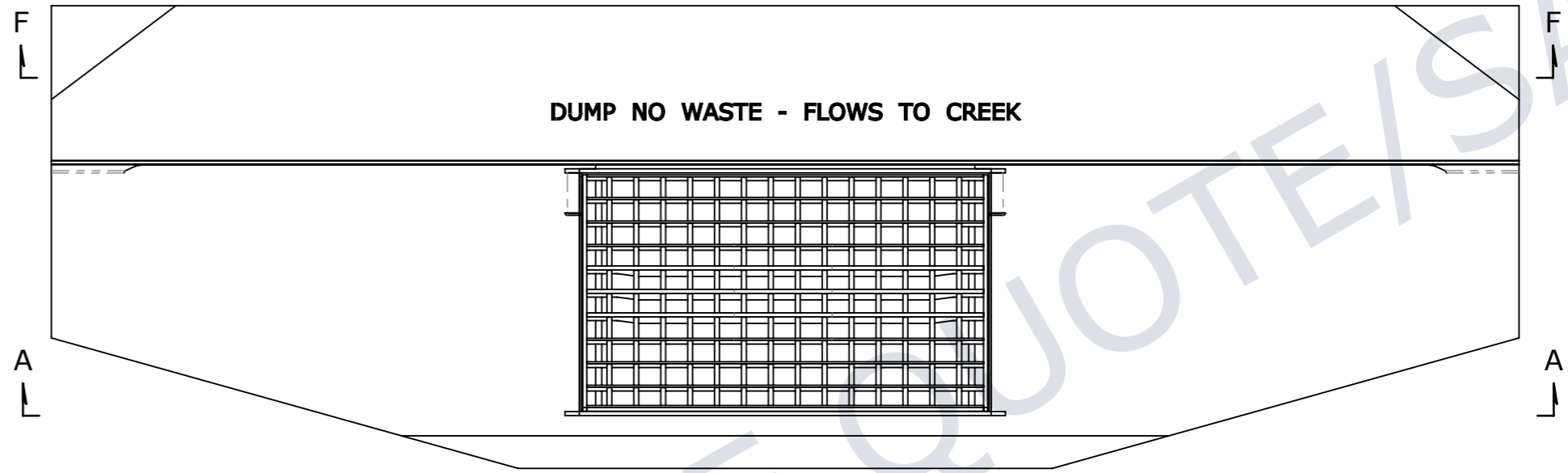

DUMP NO WASTE - FLOWS TO CREEK

PLAN VIEW

MANUFACTURER'S
BRAND IDENTITY
POSITIONED CENTRAL



SECTION F-F

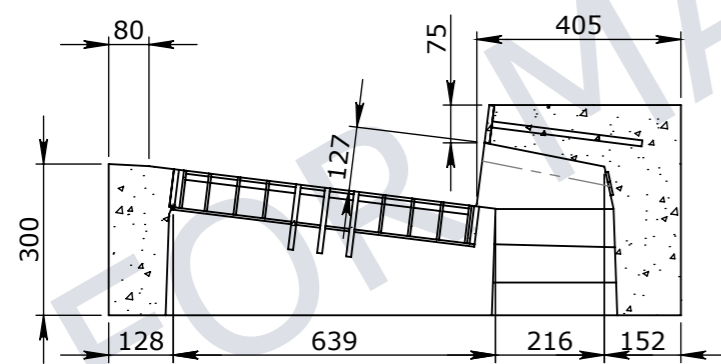

SECTION H-H

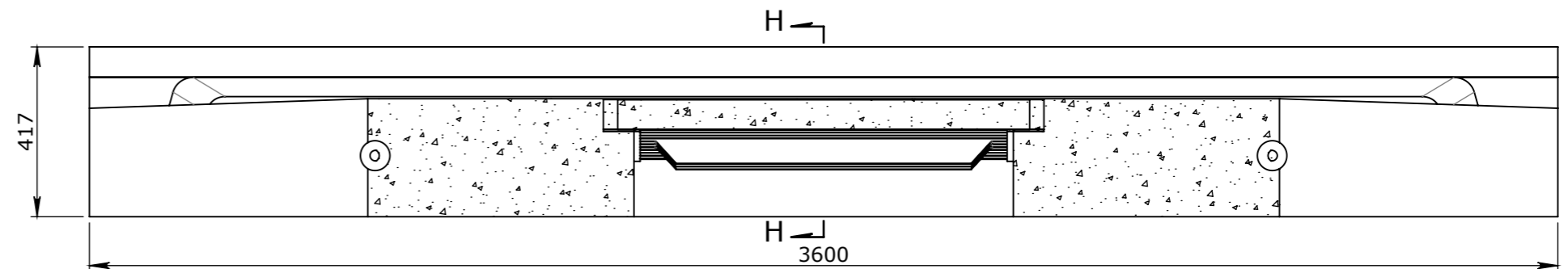

SECTION A-A

UNCONTROLLED DOCUMENT WHEN PRINTED



VICTORIA:
CARNHAM ROAD
BALLARAT, VIC 3351
QLD:
91 STRADBROKE STREET
HEATHWOOD, QLD 4110
DRAWN TO AS 1100
DO NOT SCALE
FROM SHEET

NAME:
KERB UNIT INTAKE TMR KIL SAG 3600mm

DRAWING No:
50207102

DRAFTED BY:
DPRUSAC

DRAFTED DATE:
30/03/2022

PAGE:
2 / 2

SHEET:
A3

REV
A
SCALE UNO:
1:15