

CONCRETE NOTE:

- REFER TO GENERAL TOLERANCES UNO
- GRADE OF CONCRETE - 50MPA COMPLIES WITH MRTS70
- ALL LIFTING POINTS TO BE USED WHEN LIFTING
- MINIMUM STRENGTH OF CONCRETE SHALL BE 25MPA AT THE TIME OF LIFTING
- REFER TO PRECAST CONCRETE INSTALLATION GUIDE V.1 2019 FOR INSTALLATION DETAILS
- REFER TO ANCON LIFTING ARRANGEMENT PLAN
- KERB UNITS COMPLY WITH BELOW TMR STANDARDS
 - MRTS72
 - MRTS71
 - MRTS70
 - MRTS78
 - MRTS03
- GRATE AND FRAME COMPLY WITH AS3996:2019 FOR CLASS D LOAD RATING
- KERB UNITS COMPLY WITH TMR SD 1443 & 1444 TESTING CRITERIA
- EXPOSURE CLASSIFICATIONS - B2 AS PER AS3600:2017
DESIGN LIFE 50 YEARS AS PER AS3600:2017
MINIMUM COVER TO REINFORCEMENT - 25mm

NOTE:

REINFORCEMENT DESIGN IS NOT SHOWN.
REINFORCEMENT DESIGN COMPLIES WITH TMR SD 1443 & 1444 LOADING REQUIREMENT AND OTHER TMR STANDARDS.

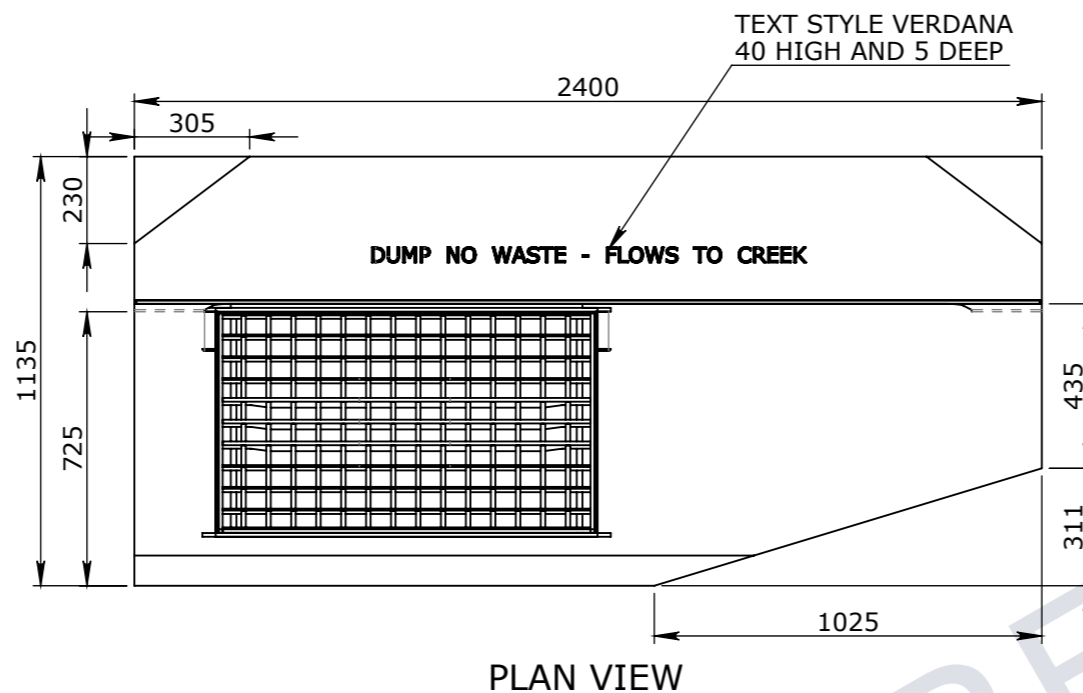

TMR APPROVED
GR/FR 900 X 600
CLASS D HINGE

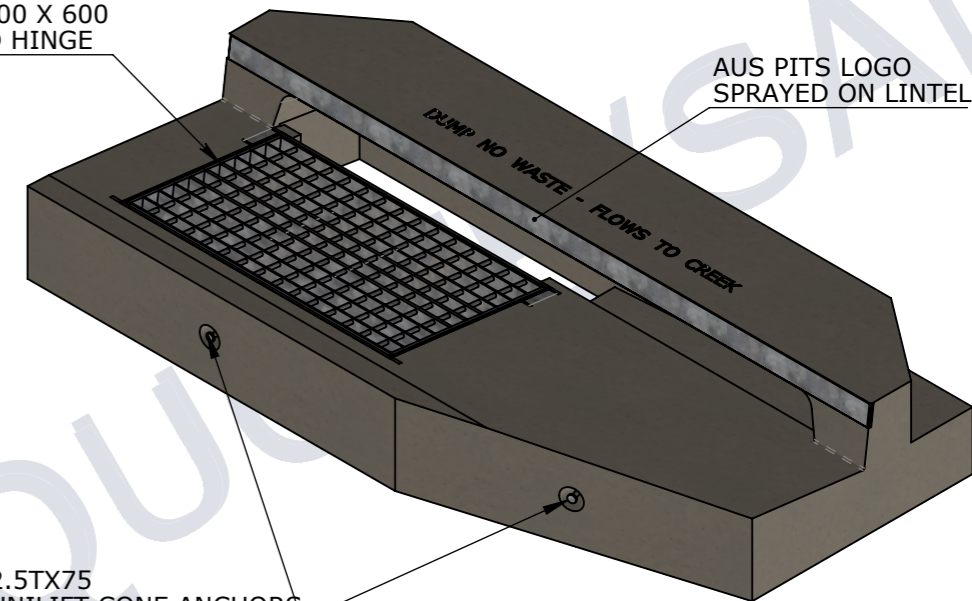

4PCS X 2.5TX75
ANCON UNILIFT CONE ANCHORS

ISOMETRIC VIEW

PLAN VIEW

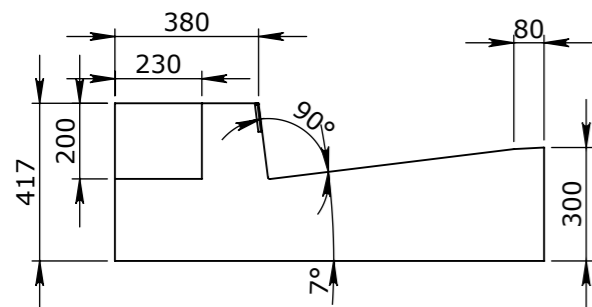

END VIEW

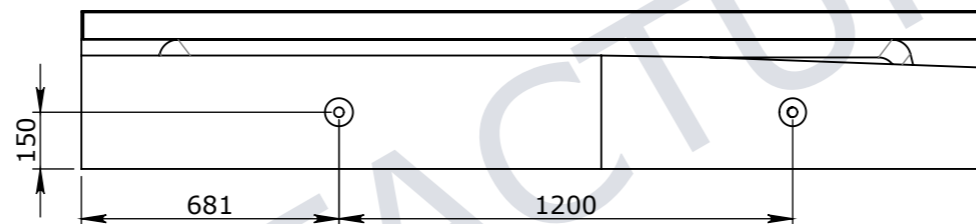

ELEVATION VIEW

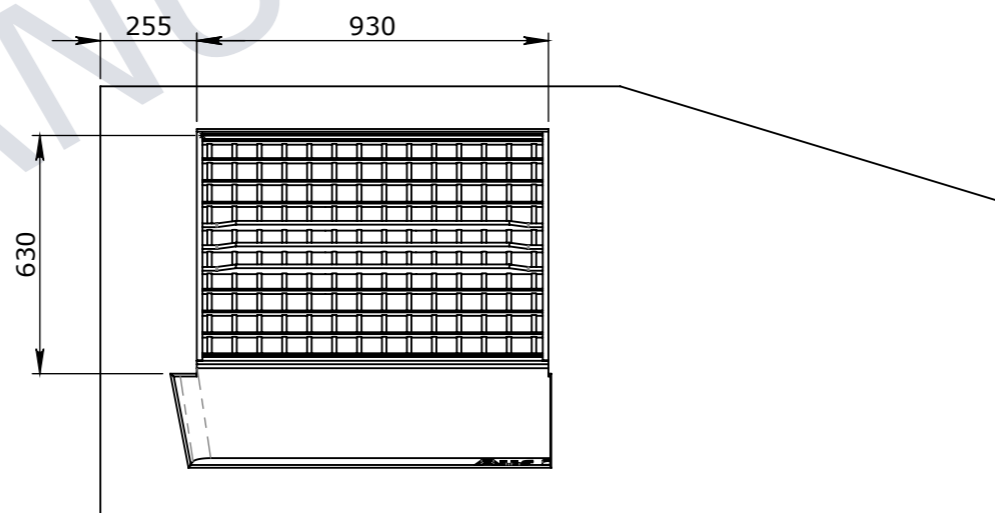

UNDERSIDE VIEW

UNCONTROLLED DOCUMENT WHEN PRINTED

TOLERANCE NOTES:

- CONCRETE TOLERANCES TO BE IN CONJUNCTION / ACCORDANCE WITH AS3600 - CONCRETE STRUCTURES
- WHEN A BROOME FINISH IS REQUIRED THE GENERAL TOLERANCE SUPERCEDES THE FLATNESS TOLERANCE
- WALL THICKNESS - DIMENSION AS NOTED IS MINIMUM THICKNESS ONLY
- CONCRETE GRADE - 40MPA UNLESS NOTED OTHERWISE
- DIMENSIONS ARE NOT INCLUSIVE OF SEALANTS OF JOINTS
- SURFACE FINISH - CLASS 4 (AS3610.1)

Rev	DESCRIPTION	DATE	BY	APPROVED
3				
2				
1				

GENERAL TOLERANCES		REVISION CONTROL	
NOMINAL:	UP TO 1000mm	1M AND ABOVE	FLATNESS: (NOT INCLUDING BROOME FINISH)
TOLERANCE:	±5mm	1mm IN 200mm UP TO A MAXIMUM OF 20mm	±4mm PER 1M WIDTH IN 1M LENGTH

CHK / APPR:	AC
DATE:	
RPEQ DOCUMENT #:	
WEIGHT:	1278.7Kg
MATERIAL:	
IRF REF:	

CUBIS SYSTEMS
A CRH COMPANY

HEAD OFFICE:
CARNGHAM ROAD
BALLARAT, VIC 3351
(03) 5335 8741

ENGINEERING & DEVELOPMENT:
91 STRADBROKE STREET
HEATHWOOD, QLD 4110
(07) 3714 0444

THE INFORMATION DISCLOSED IN THIS DOCUMENT IS CONFIDENTIAL AND IS NOT WITHOUT THE EXPRESS CONSENT OF CUBIS SYSTEMS

AUSTRALIA TO BE COPIED, REPRODUCED, OR GIVEN TO ANY OTHER PARTY IN ANY FORM AND THAT ALL COPYRIGHT, DESIGNS AND PATENTS VEST IN CUBIS SYSTEMS AUS.

DRAFTED DATE:	28/08/2020
DRAFTED BY:	DPRUSAC
DATE LAST SAVED:	4/11/2021
LAST SAVED BY:	CABEYSINGH
DRAWN TO AS 1100	DO NOT SCALE FROM SHEET

PART/PRODUCT #	50205168	QUOTE #		ORDER #	
REINFORCEMENT COMPUTATION		PIT #		ITEM TYPE	
CLIENT	DEPARTMENT OF TRANSPORT AND MAIN ROADS				
PROJECT DESC	TMR KERB UNITS				
DRAWING NAME	KERB UNIT INTAKE KIL RIGHT HAND 2400mm				
DRAWING #	50205168	PAGE	1 / 2	SHEET SIZE	A3
SCALE	1:20	REV.	3		

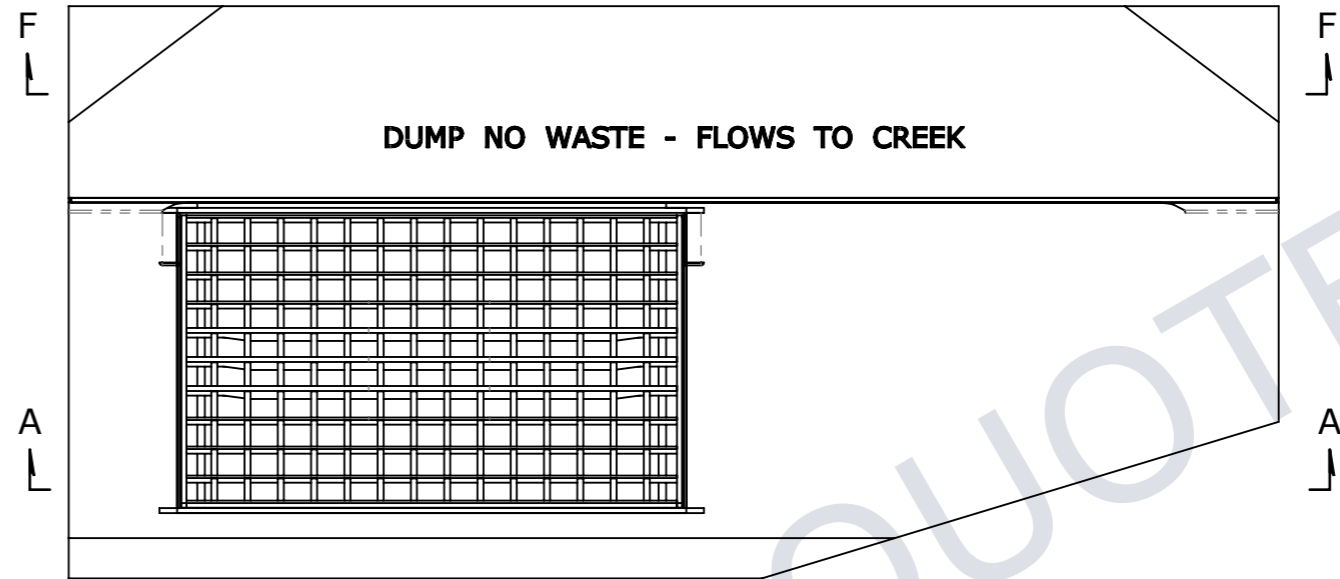

PLAN VIEW

MANUFACTURER'S
BRAND IDENTITY
POSITIONED CENTRAL



SECTION F-F

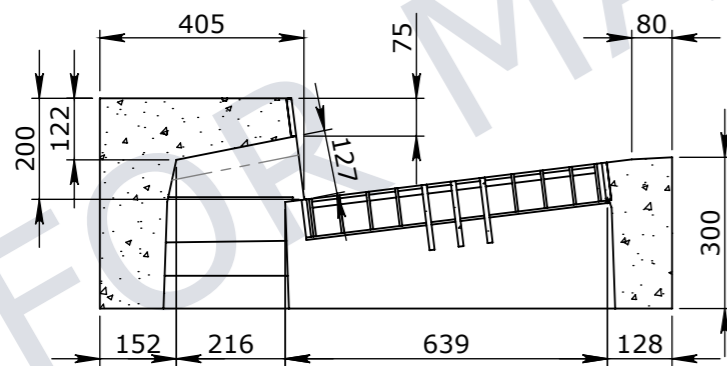

SECTION C-C

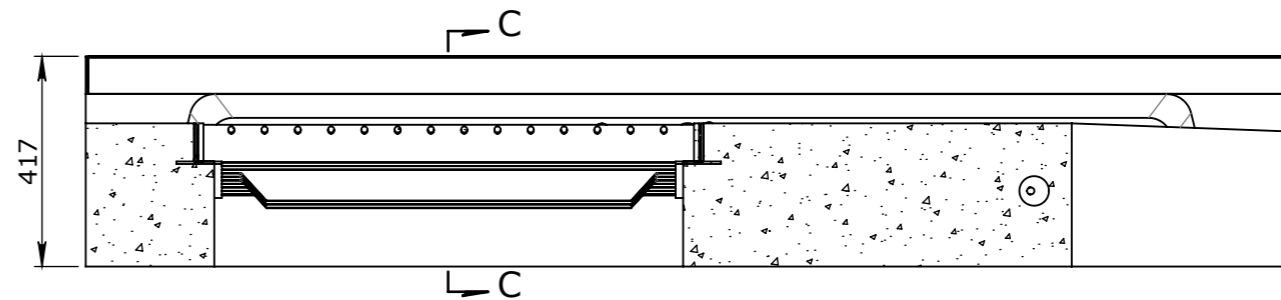

SECTION A-A

UNCONTROLLED DOCUMENT WHEN PRINTED



VICTORIA:
CARNHAM ROAD
BALLARAT, VIC 3351
QLD:
91 STRADBROKE STREET
HEATHWOOD, QLD 4110
DRAWN TO AS 1100
DO NOT SCALE
FROM SHEET

NAME: KERB UNIT INTAKE KIL RIGHT HAND 2400mm		REV 3
DRAWING No: 50205168		
DRAFTED BY: DPRUSAC	DATE LAST SAVED: 4/11/2021	PAGE: 2/2
SHEET: A3	SCALE UNO: 1:15	