

DETAIL A
SCALE_1:2

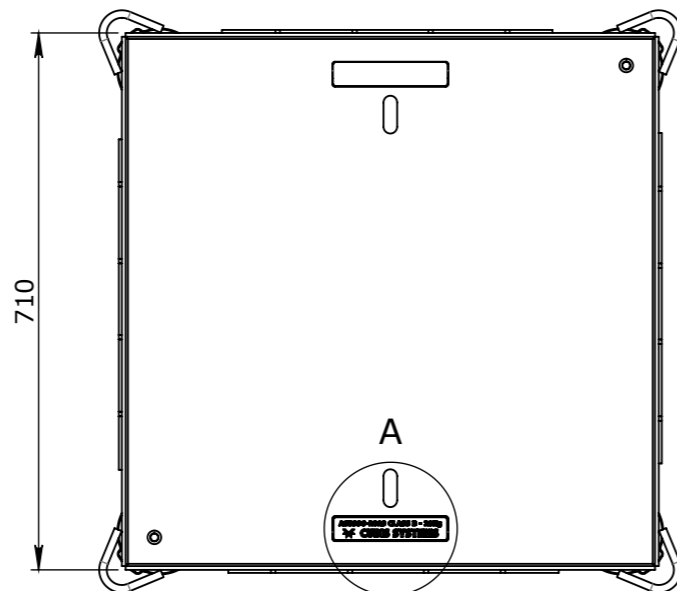

PLAN VIEW

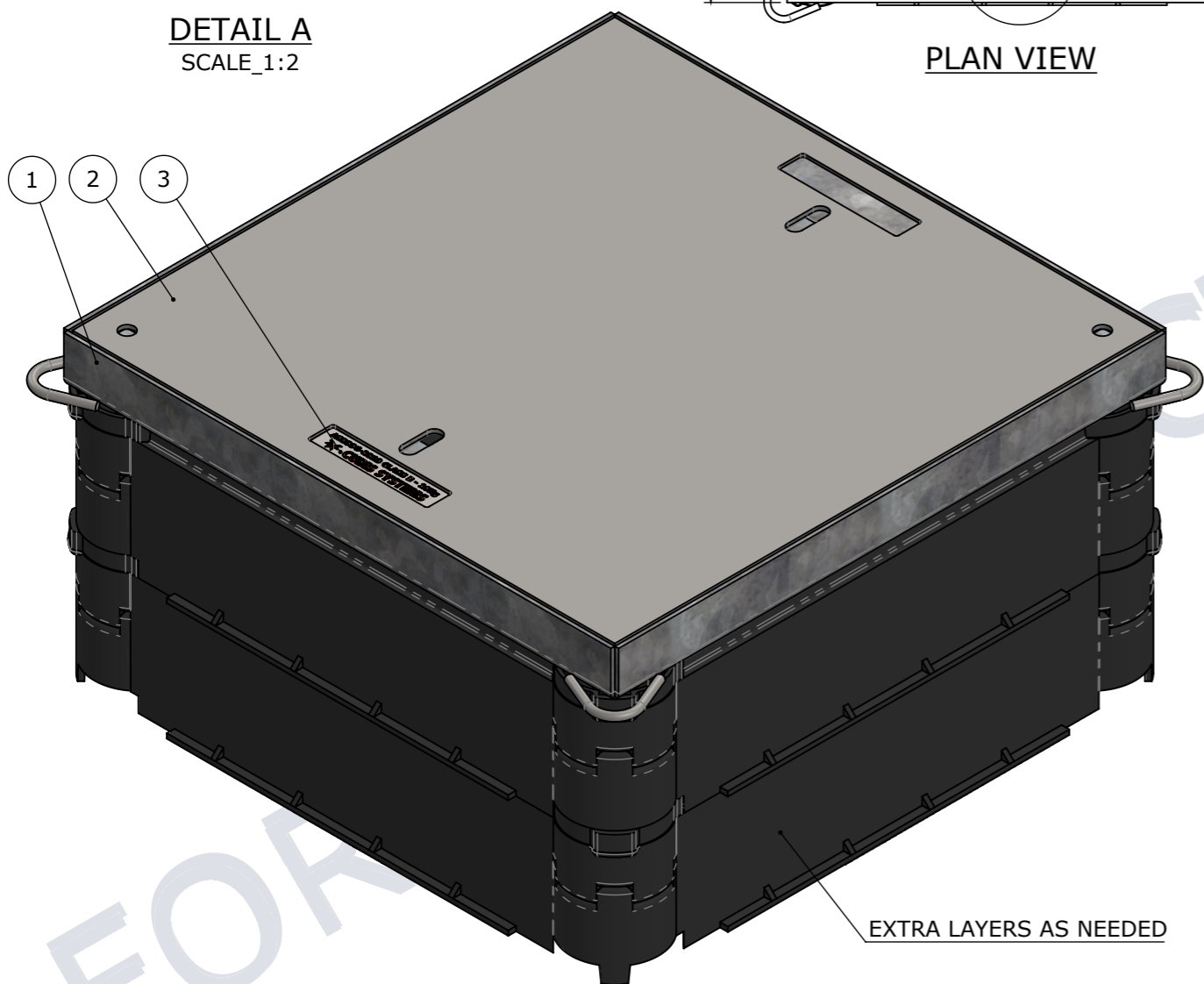

FORTRESS 600x600

BOM:50204844

ITEM #	QTY.	PART #	DESCRIPTION	WEIGHT
1	1	NPD20-017-05-01	CUBIS GMS COVER, FRAME	15.76
2	1	NPD20-017-05-02	CUBIS GMS COVER, LID	27.53
3	1	NPD20-017-05-03	600X600 GMS NAME PLATE	0.0
4	4	50201118	STAKKABOX CONNECT HS LEFT 600mm	1.98
5	4	50201141	STAKKABOX CONNECT HS RIGHT 600mm	3.94

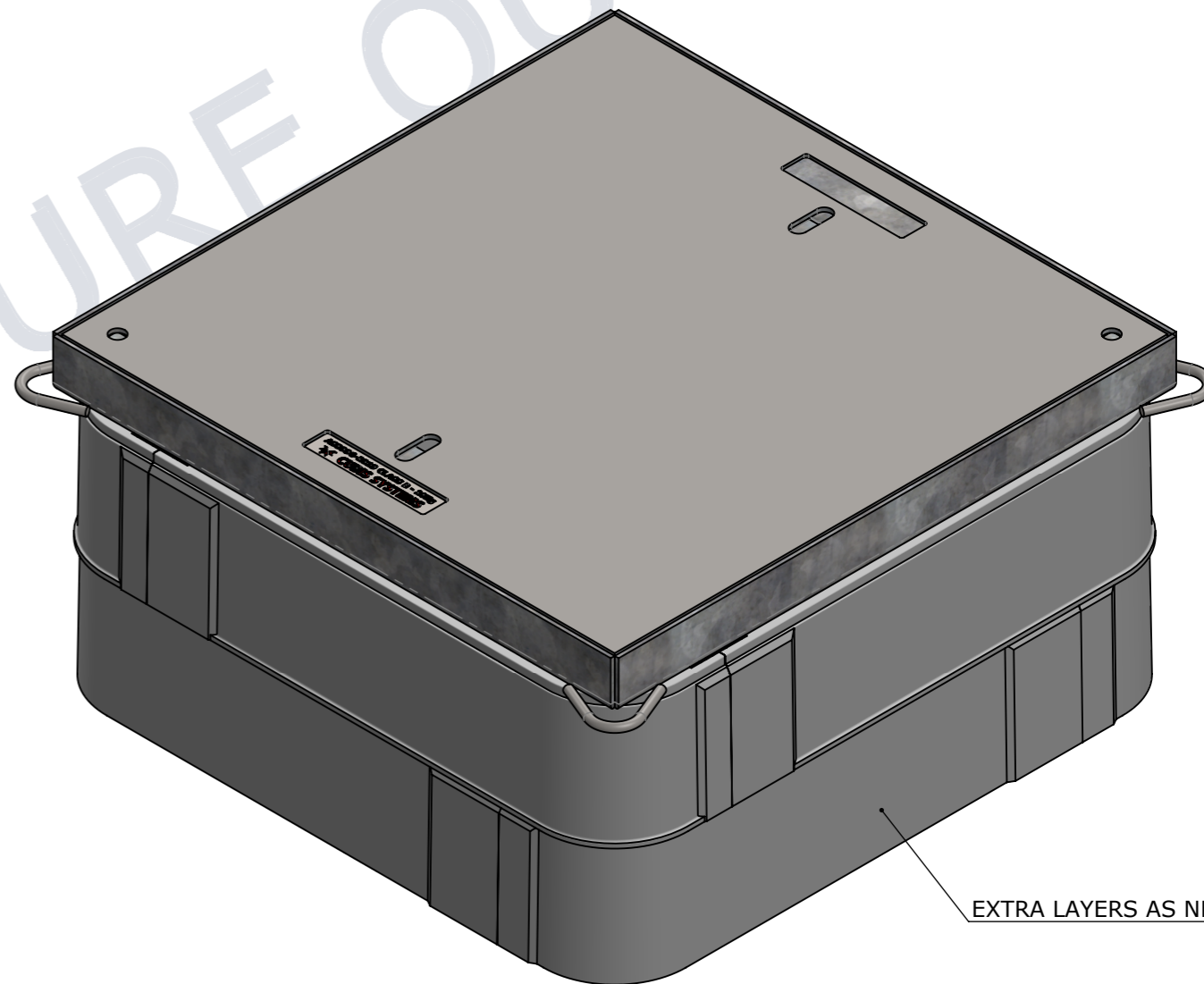

EXTRA LAYERS AS NEEDED

ULTIMA 600x600

UNCONTROLLED DOCUMENT WHEN PRINTED

- TOLERANCE NOTES:**
1. CONCRETE TOLERANCES TO BE INCONJUNCTION / ACCORDANCE WITH AS3600 - CONCRETE STRUCTURES
 2. WHEN A BROOME FINISH IS REQUIRED THE GENERAL TOLERANCE SUPERCEEDS THE FLATNESS TOLERANCE
 3. WALL THICKNESS - DIMENSION AS NOTED IS MINIMUM THICKNESS ONLY
 4. CONCRETE GRADE - 40MPA UNLESS NOTED OTHERWISE
 5. DIMENSIONS ARE NOT INCLUSIVE OF SEALANTS OF JOINTS
 6. SURFACE FINISH - CLASS 4 (AS3610.1)

Rev	DESCRIPTION	DATE	BY	APPROVED
3				
2				
1				

GENERAL TOLERANCES		REVISION CONTROL	
NOMINAL:	UP TO 1000mm	1M AND ABOVE	FLATNESS: (NOT INCLUDING BROOME FINISH)
TOLERANCE:	±5mm	1mm IN 200mm UP TO A MAXIMUM OF 20mm	±4mm PER 1M WIDTH IN 1M LENGTH

CHK / APPR:	
DATE:	
RPEQ DOCUMENT #:	
WEIGHT:	57.04Kg
MATERIAL:	
IRF REF:	



HEAD OFFICE:
CARNHAM ROAD
BALLARAT, VIC 3351
(03) 5335 8741

ENGINEERING & DEVELOPMENT:
2 STRADBROKE STREET
HEATHWOOD, QLD 4110
(07) 3714 0444

THE INFORMATION DISCLOSED IN THIS DOCUMENT IS CONFIDENTIAL AND IS NOT WITHOUT THE EXPRESS CONSENT OF CUBIS SYSTEMS AUSTRALIA TO BE COPIED, REPRODUCED, OR GIVEN TO ANY OTHER PARTY IN ANY FORM AND THAT ALL COPYRIGHT, DESIGNS AND PATENTS VEST IN CUBIS SYSTEMS AUS.

DRAFTED DATE:	1/06/2020
DRAFTED BY:	
DATE LAST SAVED:	1/04/2021
LAST SAVED BY:	CABEYSINGH

PART/PRODUCT #	NPD20-016-05	QUOTE #	ORDER #
REINFORCEMENT COMPUTATION		PIT #	ITEM TYPE
CLIENT	CUBIS SYSTEMS		
PROJECT DESC	CUBIS GMS COVER PROJECT		
DRAWING NAME	600x600 GMS COVER ASSEMBLY		
DRAWING #	50204844	PAGE	1 / 2
SCALE	1:5	SHEET SIZE	A3
REV.	A		

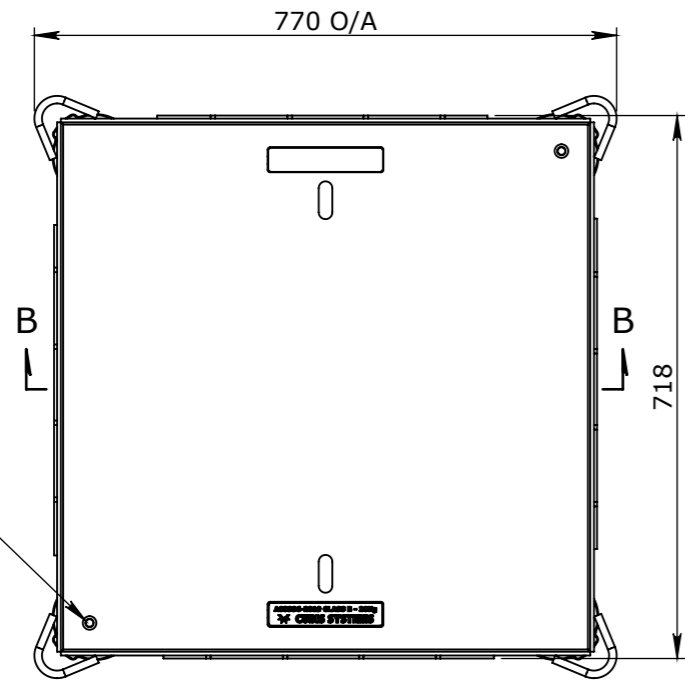

PLAN VIEW

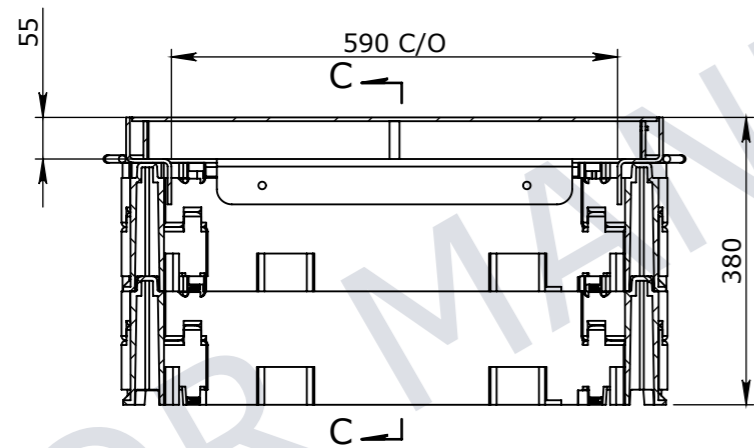
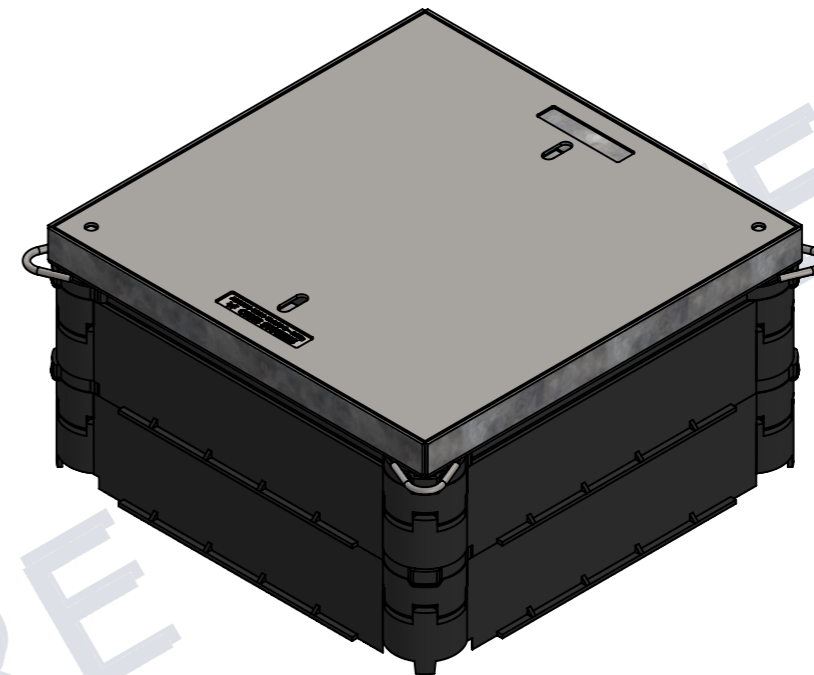

SECTION B-B

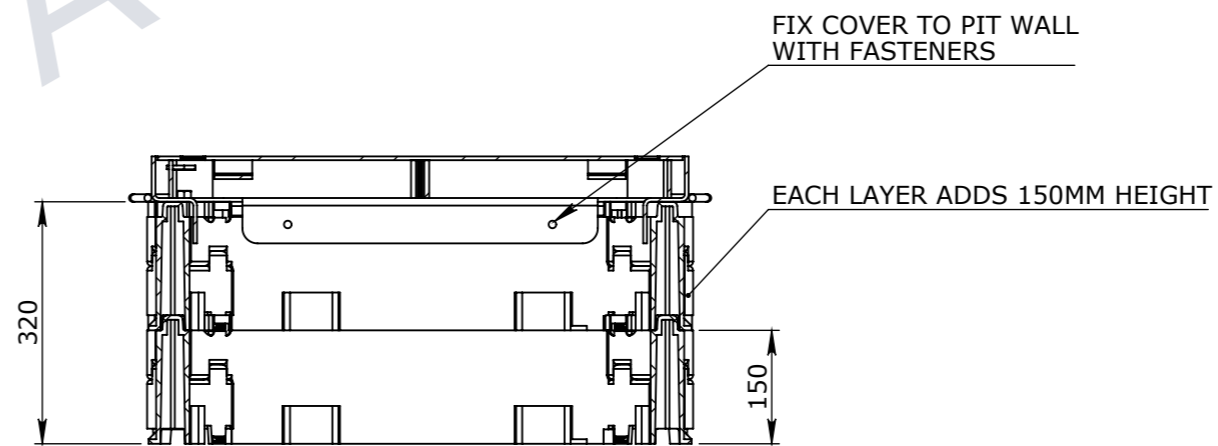

SECTION C-C

FOR MANUFACTURE



VICTORIA:
CARNHAM ROAD
BALLARAT, VIC 3351
QLD:
91 STRADBROKE STREET
HEATHWOOD, QLD 4110
DRAWN TO AS 1100
DO NOT SCALE
FROM SHEET

NAME: CUBIS GMS COVER PROJECT		REV 0
DRAWING No: 50204844		
DRAFTED BY: ACHAO	DRAFTED DATE: 30/03/2021	PAGE: 2/2
SHEET: A3		SCALE UNO: 1:10