

ZP SHROUD

PLAN VIEW

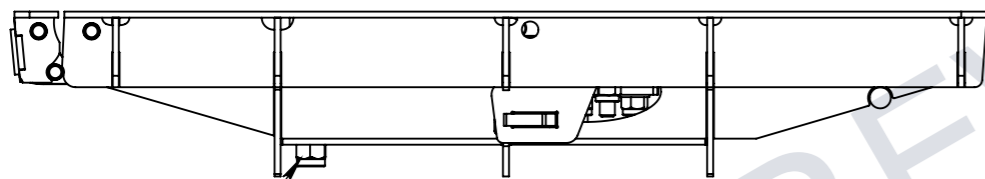

NYLOCK NUT

ELEVATION VIEW

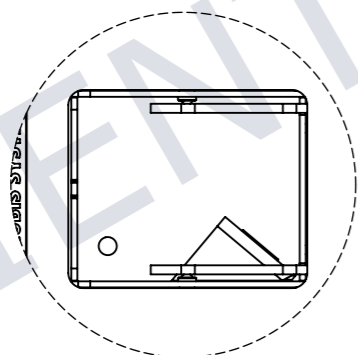

LOCK BOX DETAIL A

BOM:50201945

ITEM #	QTY.	PART#	DESCRIPTION	WEIGHT
1	1	50201992	AX S™ SCEC SL2 C5 COVER GMS BARRI BOLT	16.43
2	1	50201227-02	AX S™ SCEC SL1 C5 HINGE WELDMENT	1.02
3	4	1935304	SCEC LIDS CAST HINGE	0.19
4	3	50201227-03	AX S™ SCEC SL1 C5 HINGE PIVOT PIN	0.2
5	1	1935305	WELDMENT HATCH SCEC SL1	0.91
6	1	1935306	HANDLE SCEC	0
7	2		WASHER FLAT ZP M8	0.00
8	6		WASHER FLAT ZP M10	0.00
9	2		NYLOCK NUT ZP - M8	
10	3		NYLOCK NUT ZP - M10	
11	3	50201162	BOLT HEX ZP M10X35 CLASS 4.6	0.03
12	1	1935301	PLATE ROTATING SCEC SL1	0.34
13	1	50201227-04	AX S™ SCEC SL1 C5 LOCKING ARM 1	0.43
14	1	50201227-05	AX S™ SCEC SL1 C5 LOCKING ARM 2	0.40
15	1	1935302	PIN HATCH PIVOT SCEC SL1	
16	2	1935303	SPRING HATCH SCEC SL1	
17	1	50201227-06	SL1 -C5 - GMS NAME PLATE	0.03

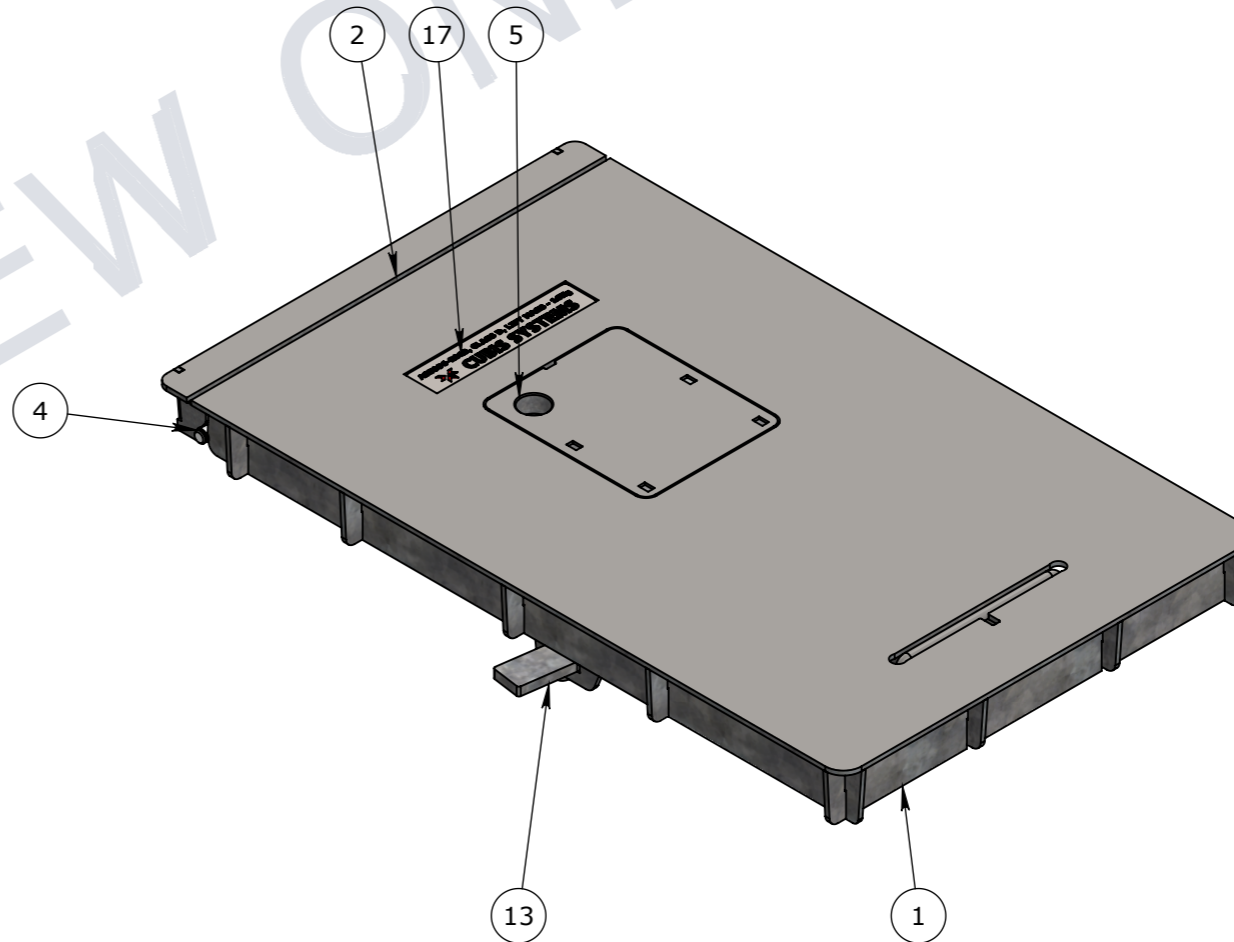

ISOMETRIC VIEW

UNCONTROLLED DOCUMENT WHEN PRINTED

- MATERIAL SPECIFICATIONS UNO SECTIONS & FLATS - AS 3679 - GR 300+ PLATES AS 3678 - GR 250 SHS AS 1163 - GR 350
- WELDING TO COMPLY TO AS 1554.1 UNO

GENERAL TOLERANCES				
NOMINAL SIZE	UP TO 150	ABOVE 150 UP TO 500	ABOVE 500	ANGULAR
TOL	±1.0	±2.0	±5.0	∠ X.X±0°30'
				∠ X ± 1°

TOLERANCES - FABRICATION		
LINEAR X.XX ± 0.02	FACES SQUARE ⊥ 0.05/100	ANGULAR ∠ X.X ± 0°30' DIA. CONC WITHIN Ⓞ 0.05 TIR
LINEAR X.X ± 0.1	FACES PARALLEL// 0.05/100	ANGULAR ∠ X ± 1° EDGES CHAMFERED 1.0 x 45°
LINEAR X. ± 0.25	FACES FLAT ▽ 0.05/100	GENERAL SURFACE FINISH Ra ^{3.2} √

REVISION CONTROL			
Rev	DESCRIPTION	DATE:	BY:
			ECO#:

CHK / APPR:	CA
DATE:	
RPEQ DOCUMENT #:	
WEIGHT:	21.32Kg
MATERIAL:	
SURFACE TREATMENT:	

HEAD OFFICE:
CARNINGHAM ROAD
BALLARAT, VIC 3351
(03) 5335 8741

ENGINEERING & DEVELOPMENT:
91 STRADBROKE STREET
HEATHWOOD, QLD 4110
(07) 3714 0444

THE INFORMATION DISCLOSED IN THIS DOCUMENT IS CONFIDENTIAL AND IS NOT WITHOUT THE EXPRESS CONSENT OF CUBIS SYSTEMS.

AUSTRALIA TO BE COPIED, REPRODUCED, OR GIVEN TO ANY OTHER PARTY IN ANY FORM AND THAT ALL COPYRIGHT, DESIGNS AND PATENTS VEST IN CUBIS SYSTEMS AUS.

PART/PRODUCT #	SP20-049	QUOTE #		ORDER #	
REINFORCEMENT COMPUTATION		PIT #		ITEM TYPE	
CLIENT	CUBIS SYSTEMS/AUSPITS				
PROJECT DESC	BARRI BOLT ASSEMBLIES				
DRAWING NAME	SCEC SL1 COVER, C5				
DRAWING #	50201945	PAGE	1 / 1	SHEET SIZE	A3
		SCALE	1:5	REV.	A