

BILL OF MATERIALS - 50201852

ITEM #	QTY.	PART #	DESCRIPTION
1	1	50201852	WELDMENT, COVER 1
2	1	50201852	WELDMENT, COVER 2
3	1	50201852	LOCK BOX COVER
4	4	50202603	HINGE QR STYLE
5	4	50201852	PIVOT PIN
6	2	50201852	PIVOT TUBE
7	4	50201852	OUTER PIVOT TUBE
8	4	50202604	HANDLE COVER LIFTING
9	4	50201852	AX S™ COVER GMS TO SUIT 1200x1200 OPENING CLASS C
10	8		WASHER FLAT ZP M8
11	8		NYLOCK NUT ZP - M8

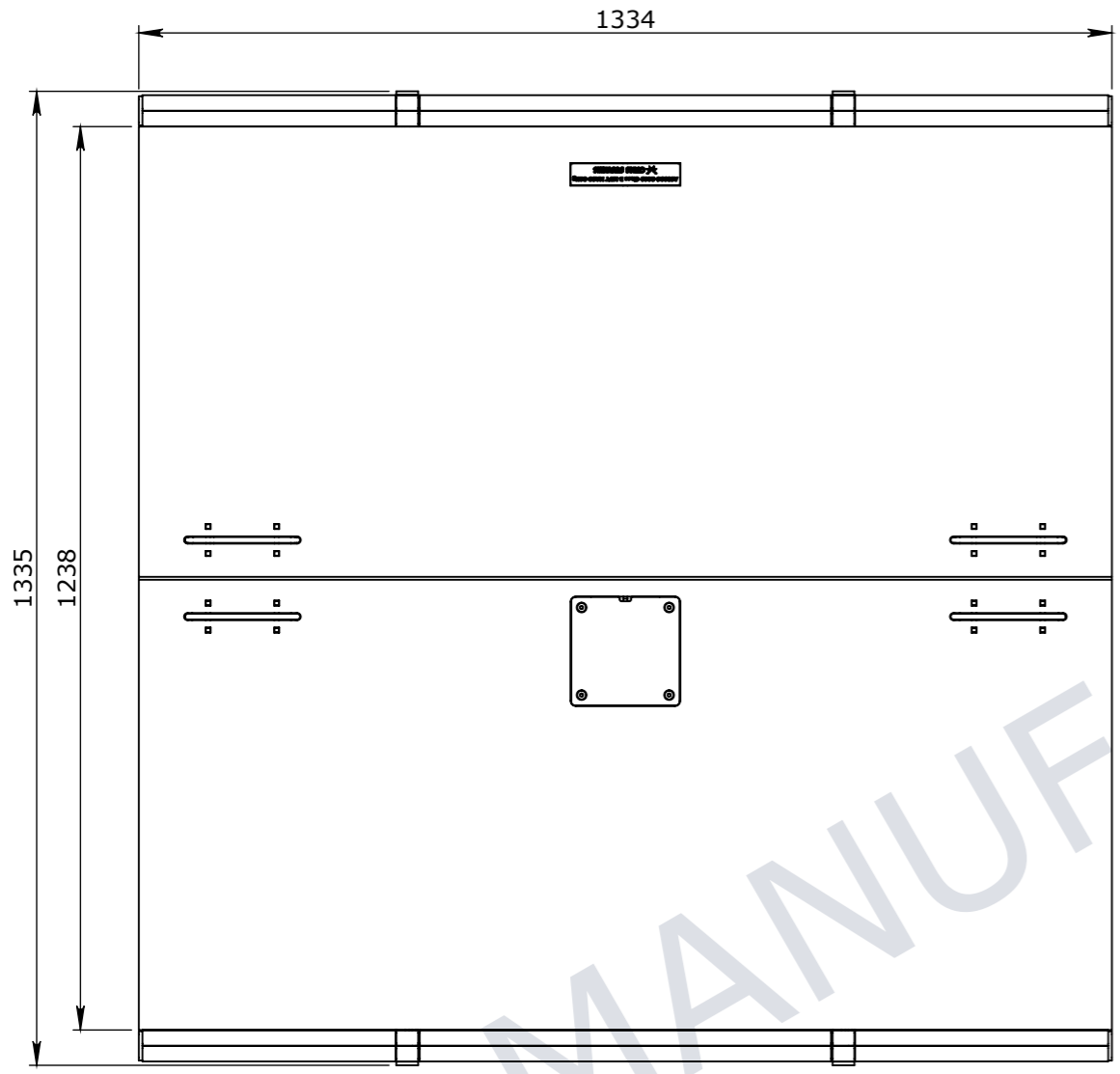

PLAN VIEW

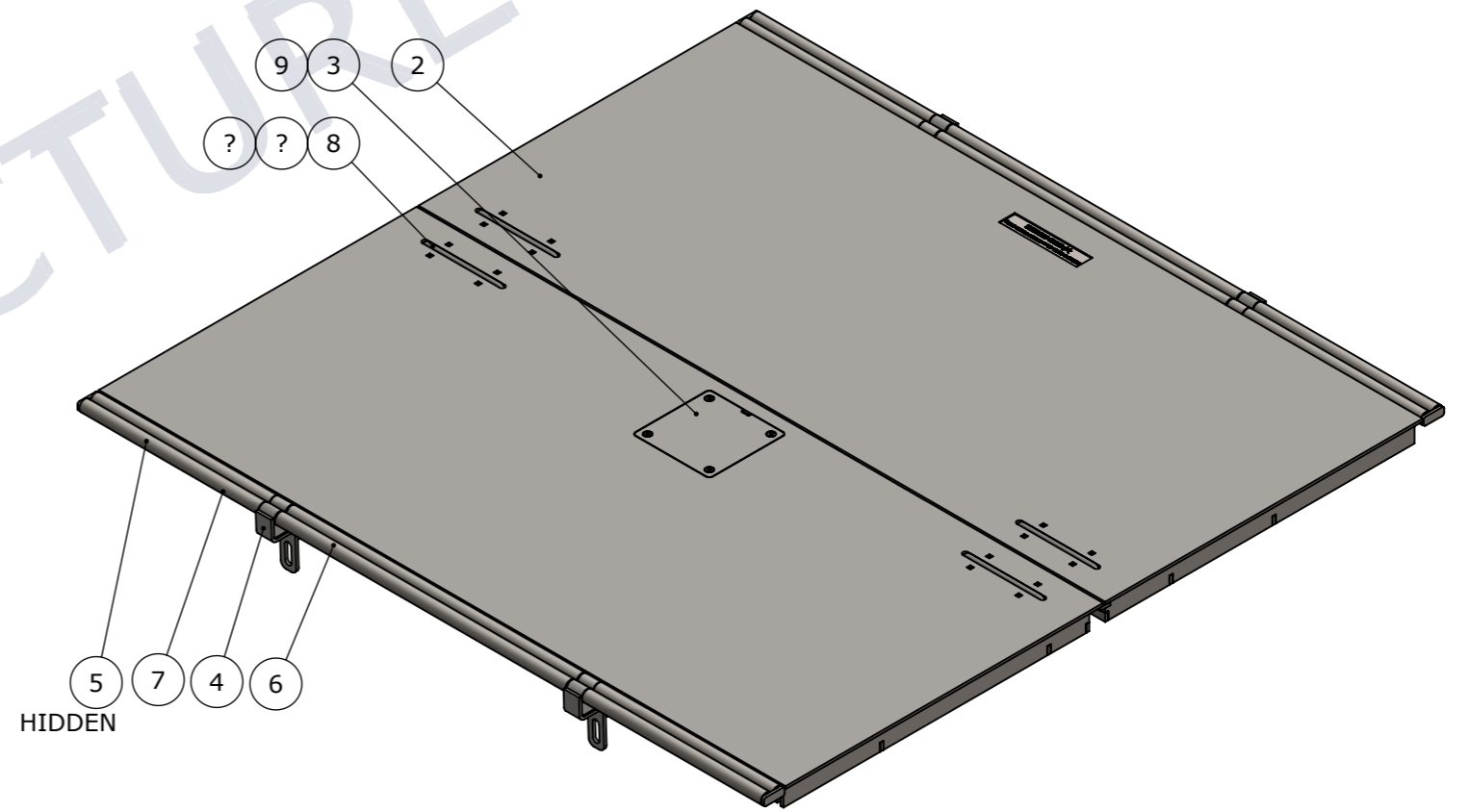

ISOMETRIC VIEW

UNCONTROLLED DOCUMENT WHEN PRINTED

- MATERIAL SPECIFICATIONS UNO SECTIONS & FLATS - AS 3679 - GR 300+ PLATES AS 3678 - GR 250 SHS AS 1163 - GR 350
- WELDING TO COMPLY TO AS 1554.1 UNO

Rev	DESCRIPTION	DATE:	BY:	ECO#:

CHK / APPR:	CA
DATE:	
RPEQ DOCUMENT #:	

HEAD OFFICE:
CARNINGHAM ROAD
BALLARAT, VIC 3351
(03) 5335 8741

ENGINEERING & DEVELOPMENT:
2 STRADBROKE STREET
HEATHWOOD, QLD 4110
(07) 3714 0444

PROJECT DESCRIPTION:	CUBIS SYSTEMS AUSTRALIA CATALOGUE PRODUCTS
DRAWING NAME:	1200x1200 GMS COVER, ASSEMBLY

GENERAL TOLERANCES				
NOMINAL SIZE	UP TO 150	ABOVE 150 UP TO 500	ABOVE 500	ANGULAR ∠ X.X±0°30'
TOL	±1.0	±2.0	±5.0	∠ X ± 1°

TOLERANCES - FABRICATION		
LINEAR X.XX ± 0.02	FACES SQUARE ⊥ 0.05/100	ANGULAR ∠ X.X ± 0°30' DIA. CONC WITHIN Ⓞ0.05 TIR
LINEAR X.X ± 0.1	FACES PARALLEL// 0.05/100	ANGULAR ∠ X ± 1° EDGES CHAMFERED 1.0 x 45°
LINEAR X. ± 0.25	FACES FLAT ▱ 0.05/100	GENERAL SURFACE FINISH Ra ^{3.2} √

REVISION CONTROL	

WEIGHT:	131.90Kg
MATERIAL:	
SURFACE TREATMENT:	

THE INFORMATION DISCLOSED IN THIS DOCUMENT IS CONFIDENTIAL AND IS NOT WITHOUT THE EXPRESS CONSENT OF CUBIS SYSTEMS AUSTRALIA TO BE COPIED, REPRODUCED, OR GIVEN TO ANY OTHER PARTY IN ANY FORM AND THAT ALL COPYRIGHT, DESIGNS AND PATENTS VEST IN CUBIS SYSTEMS AUS.

DRAWN TO AS 1100 DO NOT SCALE FROM SHEET	DRAWING No: 50201852	REV: 0
SHEET: A3	PAGE: 1/1	SCALE UNO: 1:10
DRAFTED DATE: 2/03/2016	DRAFTED BY:	