

**GENERAL NOTE:**

1. REFER TO GENERAL TOLERANCES UNO
2. GRADE OF CONCRETE - 40MPA (PRE-CAST COMPONENTS)
3. ALL PRE-CAST LIFTING POINTS TO BE USED WHEN LIFTING
4. MINIMUM STRENGTH OF CONCRETE SHALL BE 25MPA AT THE TIME OF LIFTING (PRE-CAST COMPONENTS)
5. REFER TO ANCON LIFTING ARRANGEMENT PLAN (PRE-CAST COMPONENTS)
6. FOUNDATION MATERIAL & PREPARATION PROCEEDURE REFER TO INSTALLATION GUIDE (ULTIMA CONNECT RANGE™)
7. LADDER OR STEP IRONS CAN BE SUPPLIED AS PER CLIENT REQUIREMENT

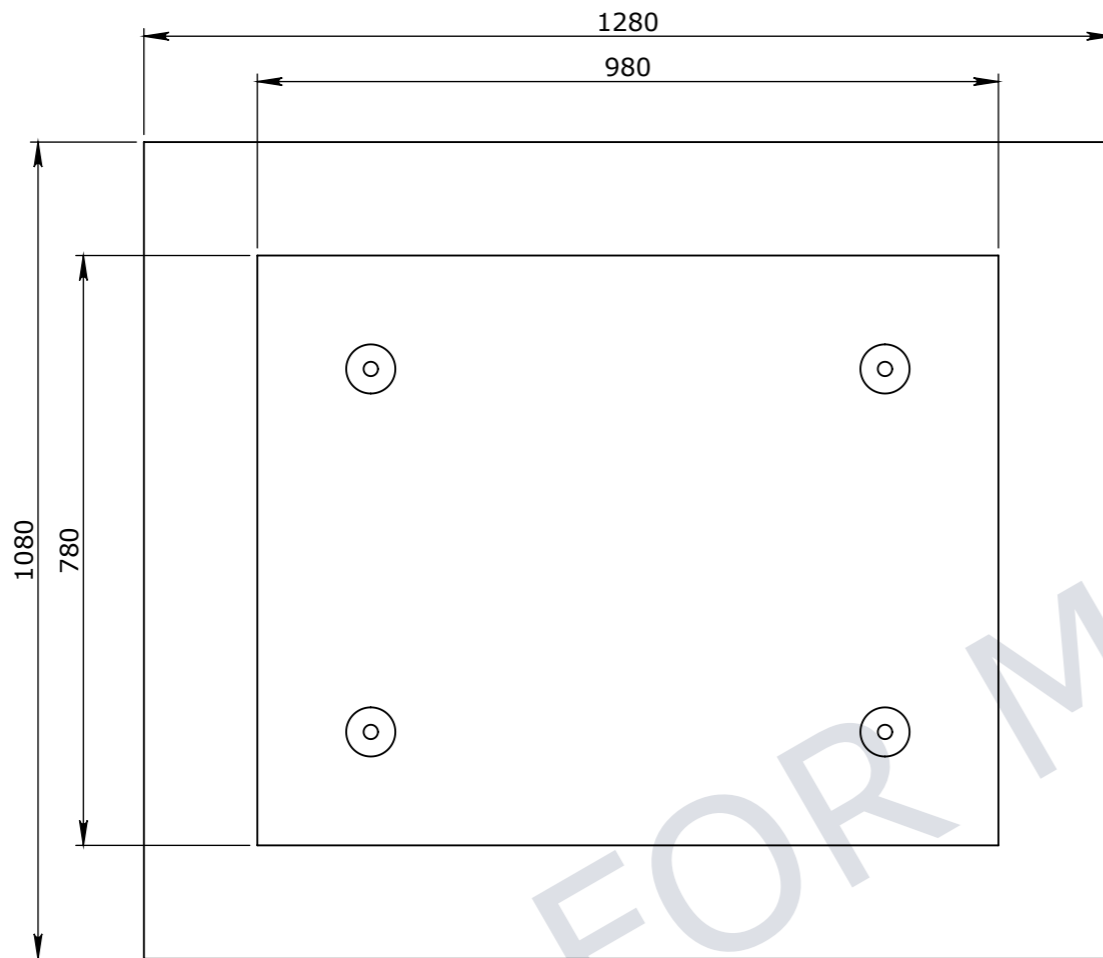

PLAN VIEW

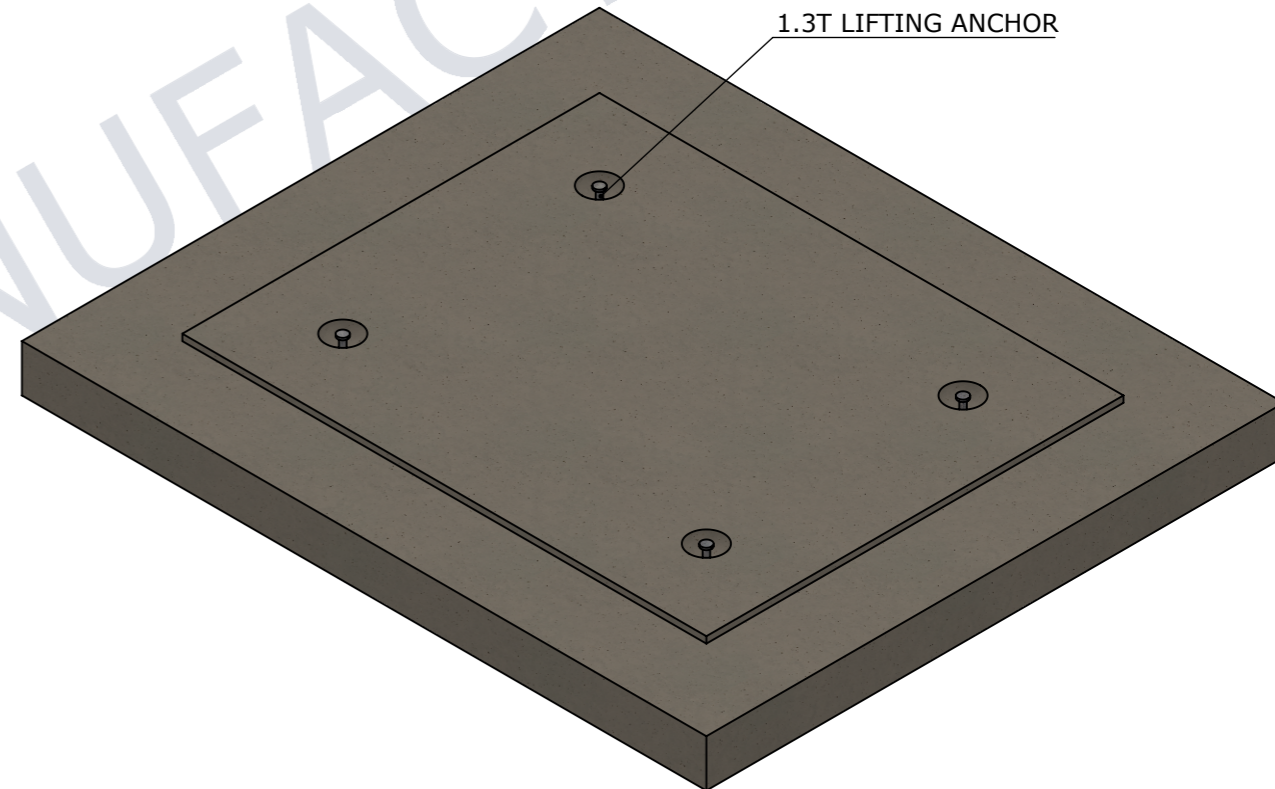

ISOMETRIC VIEW

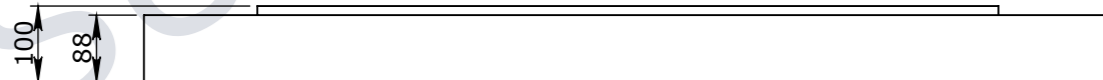

ELEVATION VIEW

UNCONTROLLED DOCUMENT WHEN PRINTED

**ISSUED FOR CLIENT REVIEW ONLY**

ISSUE	DATE	CLIENT APPROVAL
0	13/01/2020	

- TOLERANCE NOTES:**
1. CONCRETE TOLERANCES TO BE INCONJUNCTION / ACCORDANCE WITH AS3600 - CONCRETE STRUCTURES WHEN A BROOME FINISH IS REQUIRED THE GENERAL TOLERANCE SUPERCEEDS THE FLATNESS TOLERANCE
  2. WALL THICKNESS - DIMENSION AS NOTED IS MINIMUM THICKNESS ONLY
  3. CONCRETE GRADE - 40MPA UNLESS NOTED OTHERWISE
  4. DIMENSIONS ARE NOT INCLUSIVE OF SEALANTS OF JOINTS
  5. SURFACE FINISH - CLASS 4 (AS3610.1)

Rev	DESCRIPTION	DATE:	BY:	ECO#:

GENERAL TOLERANCES		REVISION CONTROL	
NOMINAL:	UP TO 1000mm	1M AND ABOVE	FLATNESS: (NOT INCLUDING BROOME FINISH)
TOLERANCE:	±5mm	1mm IN 200mm UP TO A MAXIMUM OF 20mm	±4mm PER 1M WIDTH IN 1M LENGTH

CHK / APPR:	CHANAKAA
DATE:	13-01-2020
RPEQ DOCUMENT #:	
WEIGHT:	324Kg
MATERIAL:	CONCRETE FIBRE 40MPa
SURFACE TREATMENT:	



HEAD OFFICE:  
CARNINGHAM ROAD  
BALLARAT, VIC 3351  
(03) 5335 8741

ENGINEERING & DEVELOPMENT:  
2 STRADBROKE STREET  
HEATHWOOD, QLD 4110  
(07) 3714 0444

THE INFORMATION DISCLOSED IN THIS DOCUMENT IS CONFIDENTIAL AND IS NOT WITHOUT THE EXPRESS CONSENT OF CUBIS SYSTEMS AUSTRALIA TO BE COPIED, REPRODUCED, OR GIVEN TO ANY OTHER PARTY IN ANY FORM AND THAT ALL COPYRIGHT, DESIGNS AND PATENTS VEST IN CUBIS SYSTEMS AUS.

PROJECT DESCRIPTION: <b>CUBIS SYSTEMS AUSTRALIA CATALOGUE PRODUCTS</b>				
DRAWING NAME: FLOOR CONCRETE TO SUIT BELLTOP 1100x900x1050				
DRAWN TO AS 1100 DO NOT SCALE FROM SHEET		DRAWING No: 50201723		REV: <b>0</b>
SHEET: A3	PAGE: 1/1	SCALE UNO: 1:10	DRAFTED DATE: 7/01/2020	DRAFTED BY: P.ADAMS