

**CONCRETE NOTE:**

1. REFER TO GENERAL TOLERANCES UNO
2. GRADE OF CONCRETE - 40MPA
3. ALL LIFTING POINTS TO BE USED WHEN LIFTING
4. MINIMUM STRENGTH OF CONCRETE SHALL BE 25MPA AT THE TIME OF LIFTING
5. REFER TO BVCI-INS-C-001 (STD INSTALLATION GUIDE) FOR INSTALLATION DETAILS
6. REFER TO ANCON LIFTING ARRANGEMENT PLAN

**BOM - CUT LIST**

ITEM #	QTY.	DESCRIPTION	VOLUME	MATERIAL
1	1	CONCRETE 40Mpa FIBRE MIX MP47 ES401	0.22	CONCRETE 40MPa
2	4	FOOT ANCHOR - 1.3Tx120	0	MS GR-250
3	1		0	CAST IRON

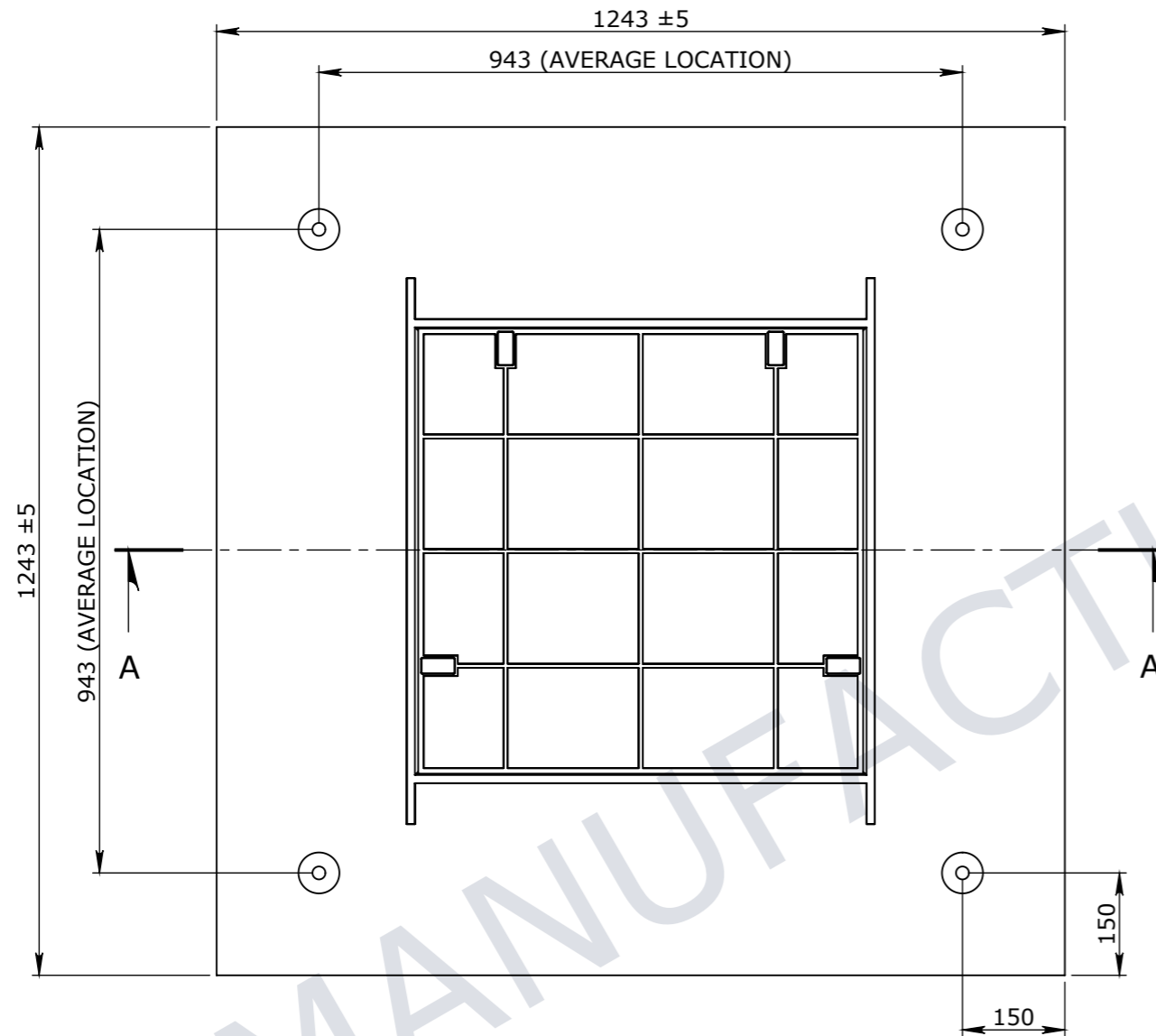

PLAN VIEW

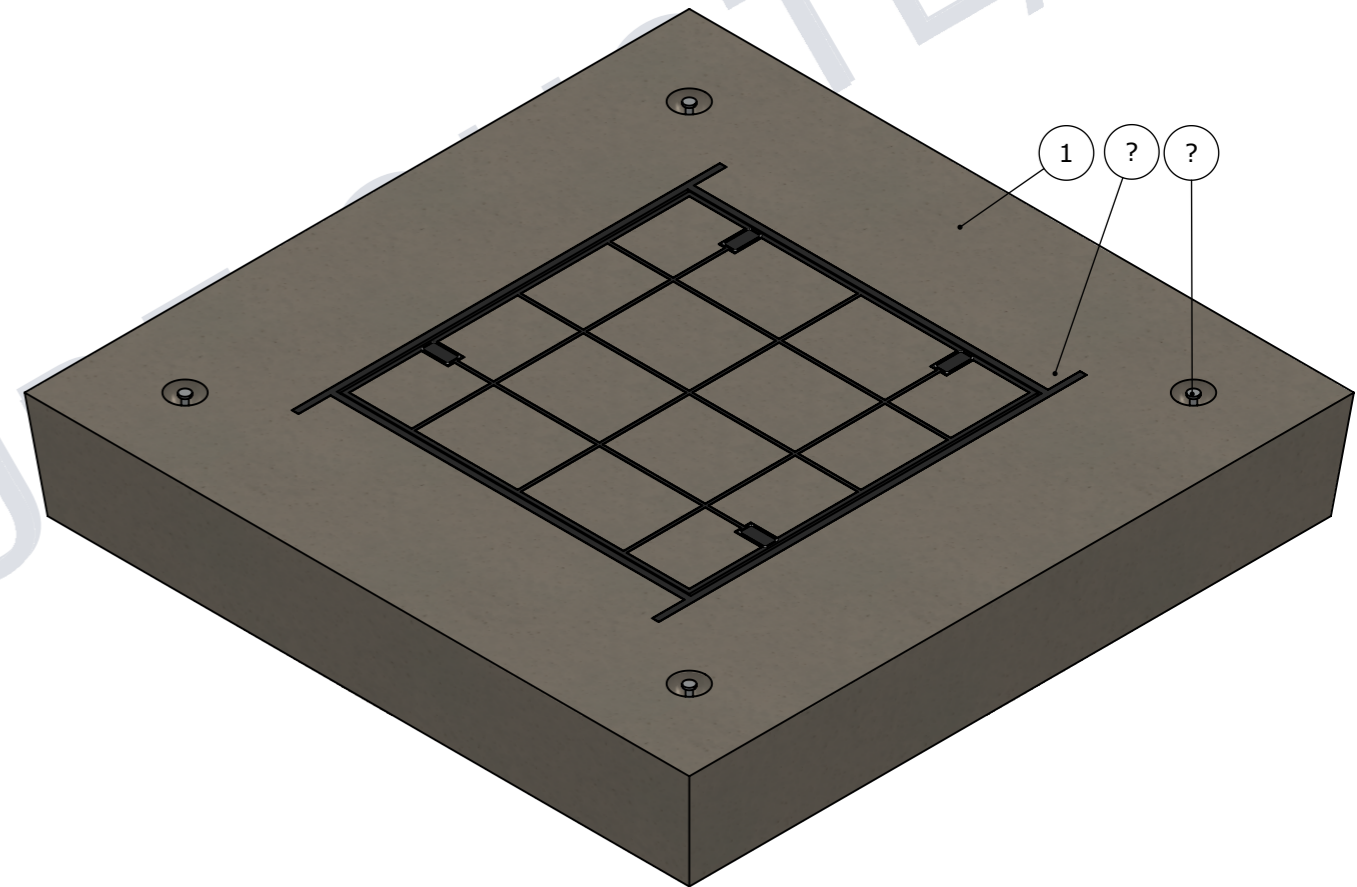

ISOMETRIC VIEW

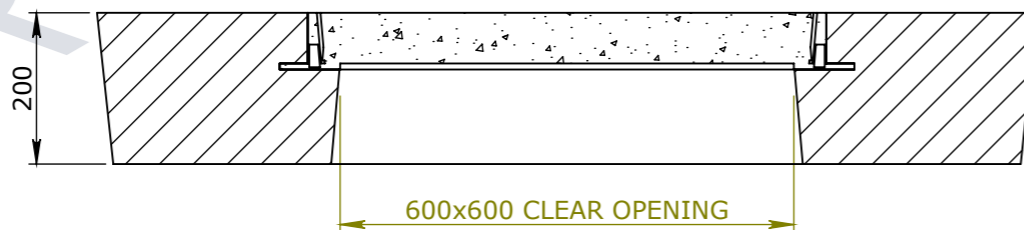

SECTION A-A

UNCONTROLLED DOCUMENT WHEN PRINTED

- TOLERANCE NOTES:**
1. CONCRETE TOLERANCES TO BE IN CONJUNCTION / ACCORDANCE WITH AS3600 - CONCRETE STRUCTURES WHEN A BROOME FINISH IS REQUIRED THE GENERAL TOLERANCE SUPERCEEDS THE FLATNESS TOLERANCE
  2. WALL THICKNESS - DIMENSION AS NOTED IS MINIMUM THICKNESS ONLY CONCRETE GRADE - 40MPA UNLESS NOTED OTHERWISE
  3. DIMENSIONS ARE NOT INCLUSIVE OF SEALANTS OF JOINTS
  4. SURFACE FINISH - CLASS 4 (AS3610.1)

Rev	DESCRIPTION	DATE:	BY:	ECO#:

GENERAL TOLERANCES		REVISION CONTROL	
NOMINAL:	UP TO 1000mm	1M AND ABOVE	FLATNESS: (NOT INCLUDING BROOME FINISH)
TOLERANCE:	±5mm	1mm IN 200mm UP TO A MAXIMUM OF 20mm	±4mm PER 1M WIDTH IN 1M LENGTH

CHK / APPR:	M.LEE
DATE:	20/10/2015
RPEQ DOCUMENT #:	
WEIGHT:	656.00Kg
MATERIAL:	CONCRETE 40MPA
SURFACE TREATMENT:	

HEAD OFFICE:  
CARNINGHAM ROAD  
BALLARAT, VIC 3351  
(03) 5335 8741

ENGINEERING & DEVELOPMENT:  
2 STRADBROKE STREET  
HEATHWOOD, QLD 4110  
(07) 3714 0444

THE INFORMATION DISCLOSED IN THIS DOCUMENT IS CONFIDENTIAL AND IS NOT WITHOUT THE EXPRESS CONSENT OF CUBIS SYSTEMS AUSTRALIA TO BE COPIED, REPRODUCED, OR GIVEN TO ANY OTHER PARTY IN ANY FORM AND THAT ALL COPYRIGHT, DESIGNS AND PATENTS VEST IN CUBIS SYSTEMS AUS.

PROJECT DESCRIPTION: <b>CUBIS SYSTEMS AUSTRALIA CATALOGUE PRODUCTS</b>			
DRAWING NAME:			
DRAWN TO AS 1100 DO NOT SCALE FROM SHEET	DRAWING No: <b>50201692</b>	REV: <b>0</b>	
SHEET: <b>A3</b>	PAGE: <b>1/1</b>	SCALE UNO: <b>1:10</b>	DRAFTED DATE: <b>30/09/2015</b>