

CONCRETE NOTE:

1. REFER TO GENERAL TOLERANCES UNO
2. GRADE OF CONCRETE - 40MPA
3. ALL LIFTING POINTS TO BE USED WHEN LIFTING
4. MINIMUM STRENGTH OF CONCRETE SHALL BE 25MPA AT THE TIME OF LIFTING
5. REFER TO BVCI-INS-C-001 (STD INSTALLATION GUIDE) FOR INSTALLATION DETAILS
6. REFER TO ANCON LIFTING ARRANGEMENT PLAN

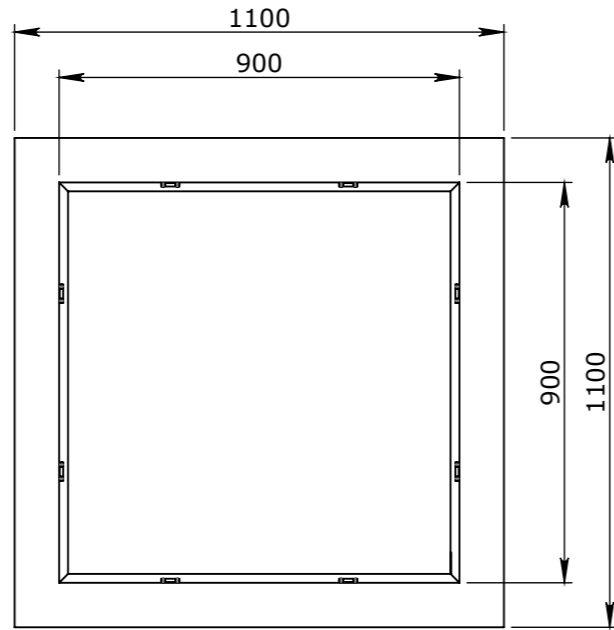

PLAN VIEW

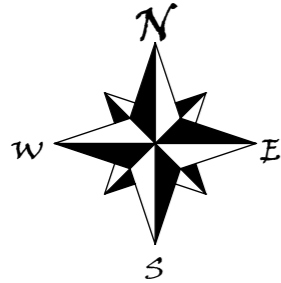
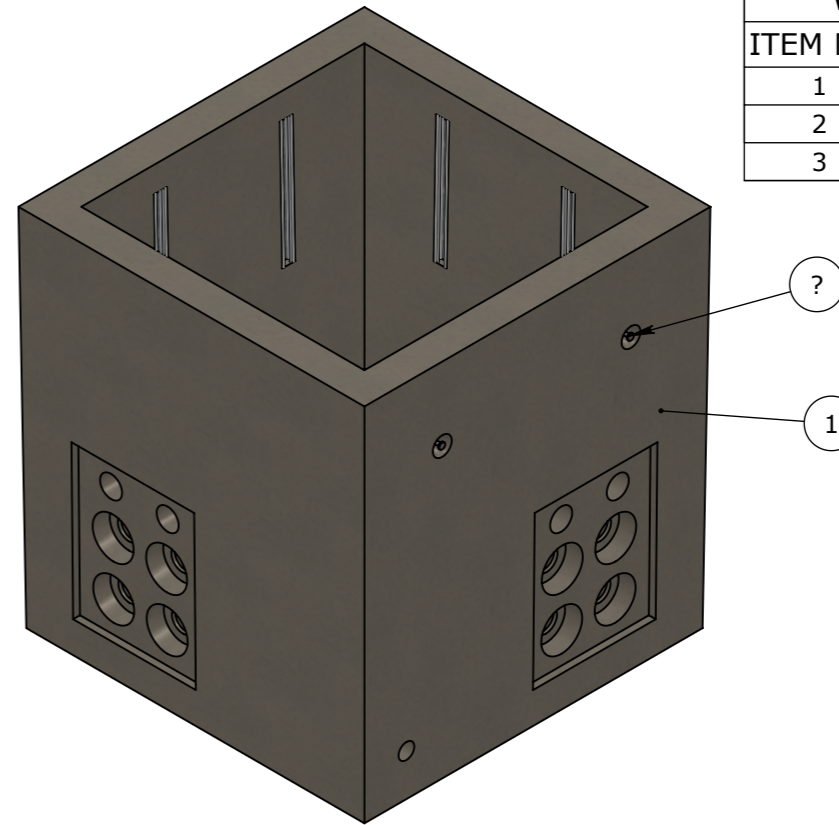

ISOMETRIC VIEW

WELDMENT CUT LIST

ITEM NO.	QTY.	DRAWING NAME
1	1	CAST PART
2	8	UNISTRUT - P3300
3	4	

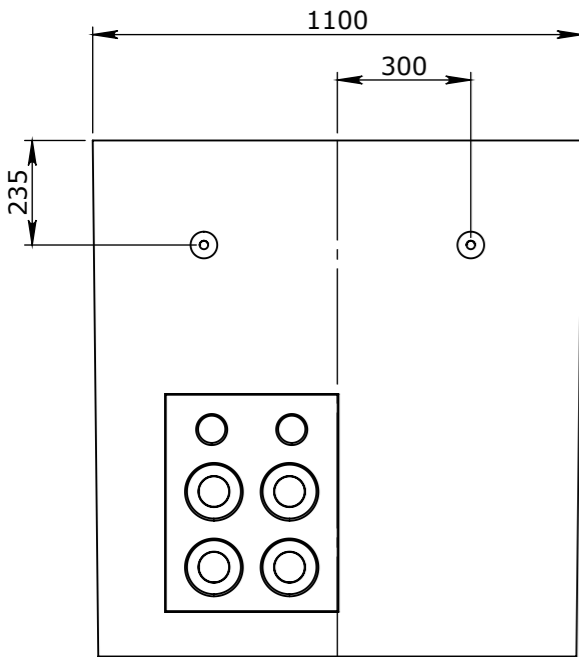

WEST FACE

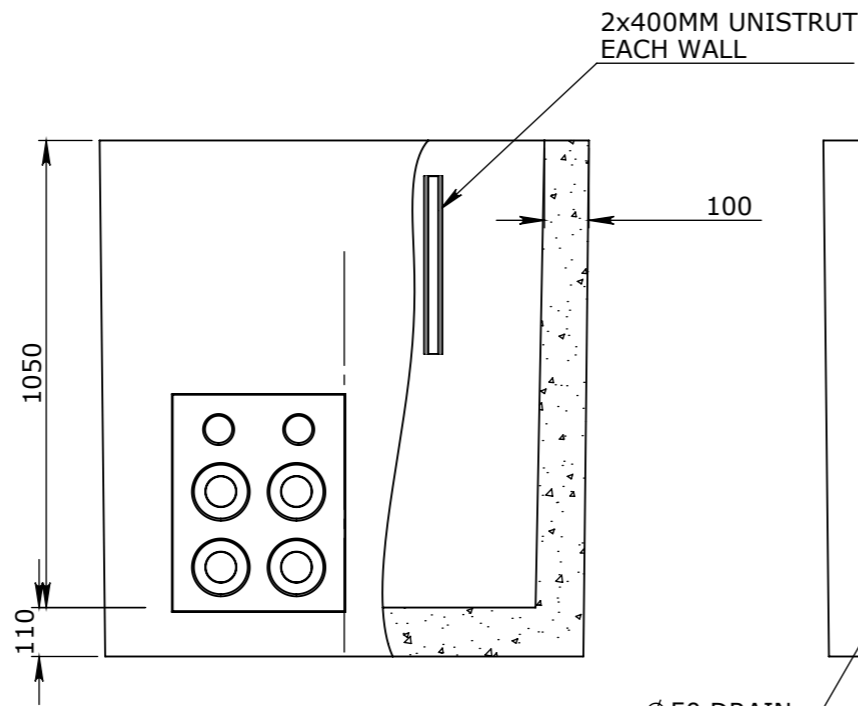

SOUTH FACE

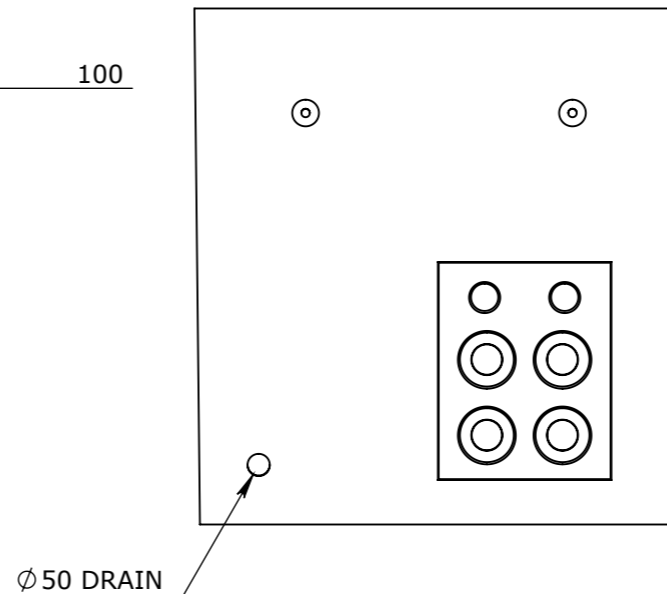

EAST FACE

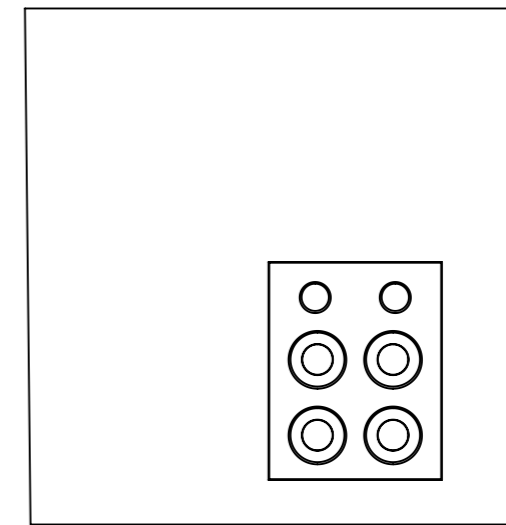

NORTH FACE

- TOLERANCE NOTES:**
1. CONCRETE TOLERANCES TO BE IN CONJUNCTION / ACCORDANCE WITH AS3600 - CONCRETE STRUCTURES
 2. WHEN A BROOME FINISH IS REQUIRED THE GENERAL TOLERANCE SUPERCEDES THE FLATNESS TOLERANCE
 3. WALL THICKNESS - DIMENSION AS NOTED IS MINIMUM THICKNESS ONLY
 4. CONCRETE GRADE - 40MPA UNLESS NOTED OTHERWISE
 5. DIMENSIONS ARE NOT INCLUSIVE OF SEALANTS OF JOINTS
 6. SURFACE FINISH - CLASS 4 (AS3610.1)

Rev	DESCRIPTION	DATE	BY	APPROVED
3				
2				
1	UPDATED KNOCKOUT AND DRAIN HOLE LOCATION	19/09/18	CA	

GENERAL TOLERANCES		REVISION CONTROL	
NOMINAL:	UP TO 1000mm	1M AND ABOVE	FLATNESS: (NOT INCLUDING BROOME FINISH)
TOLERANCE:	±5mm	1mm IN 200mm UP TO A MAXIMUM OF 20mm	±4mm PER 1M WIDTH IN 1M LENGTH

CHK / APPR:	CA
DATE:	19/09/2018
RPEQ DOCUMENT #:	
WEIGHT:	1296.55Kg
MATERIAL:	CONCRETE 40MPa

HEAD OFFICE:
CARNINGHAM ROAD
BALLARAT, VIC 3351
(03) 5335 8741

ENGINEERING & DEVELOPMENT:
2 STRADBROKE STREET
HEATHWOOD, QLD 4110
(07) 3714 0444

ALL INFORMATION DISCLOSED IN THIS DOCUMENT IS CONFIDENTIAL AND IS NOT WITHOUT THE EXPRESS CONSENT OF CUBIS SYSTEMS AUSTRALIA TO BE COPIED, REPRODUCED, OR GIVEN TO ANY OTHER PARTY IN ANY FORM AND THAT ALL COPYRIGHT, DESIGNS AND PATENTS VEST IN CUBIS SYSTEMS AUS.

DRAFTED DATE:	9/12/2015
DRAFTED BY:	
DATE LAST SAVED:	1/11/2021
LAST SAVED BY:	rpaterno
DRAWN TO AS 1100	DO NOT SCALE FROM SHEET

PROJECT:	BVCI GROUP CATALOGUE CONCRETE PRODUCTION CATALOGUE ITEM		
NAME:	900x900x1050 PIT, CLASS D		
DRAWING No:	50201645		
PROJECT / CATALOGUE CODE:	PAGE:	SHEET:	SCALE UNO:
5519910	1 / 1	A3	1:20