

**BOM:50201542-01\_PIT CONCRETE J8 CLASS B**

| ITEM # | QTY. | PART #   | DESCRIPTION              | MATERIAL             | VOLUME |
|--------|------|----------|--------------------------|----------------------|--------|
| 1      | 1    | 50201039 | FIBRE CONCRETE 40MPa     | CONCRETE FIBRE 40MPa | 0.34   |
| 2      | 4    | 50201274 | FOOT ANCHOR ZP 1.3Tx65mm | MS GR-250 GALV       |        |
| 3      | 4    | 50202465 | UNISTRUT ZP 600mm        | MS GR-250 GALV       |        |

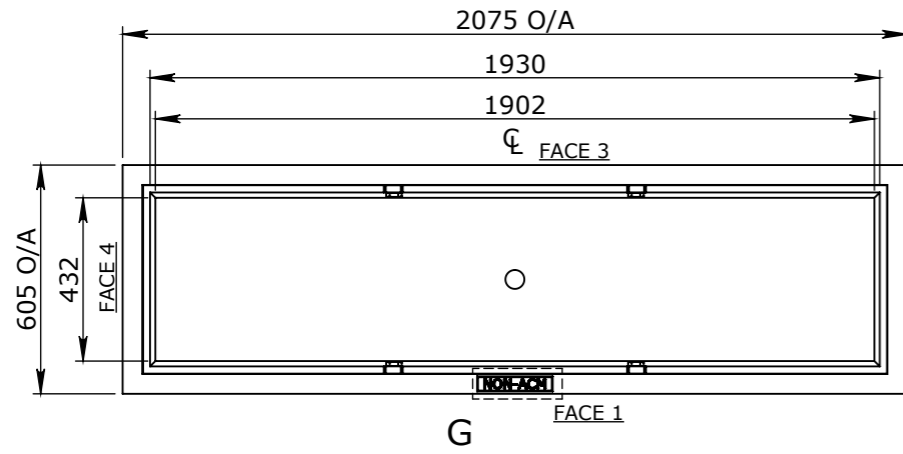

PLAN VIEW

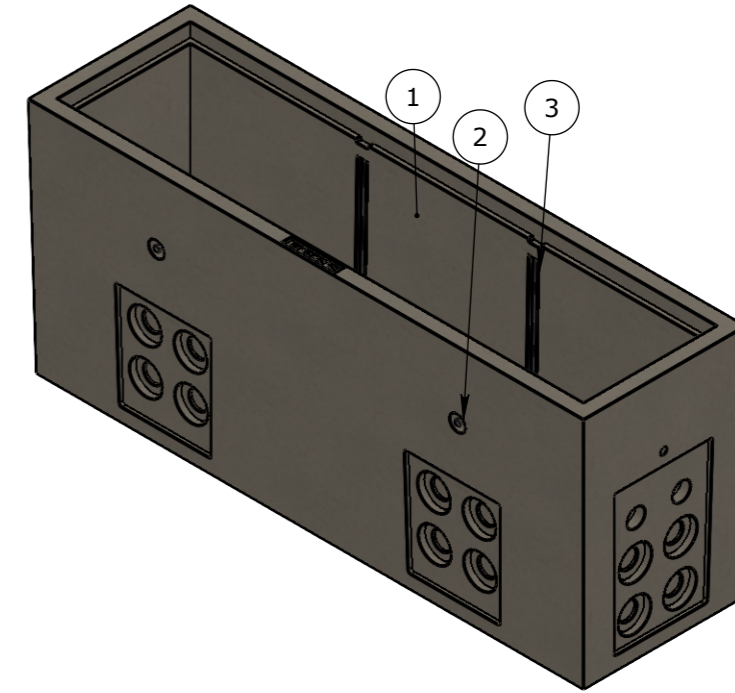

ISOMETRIC VIEW

SCALE 1:20

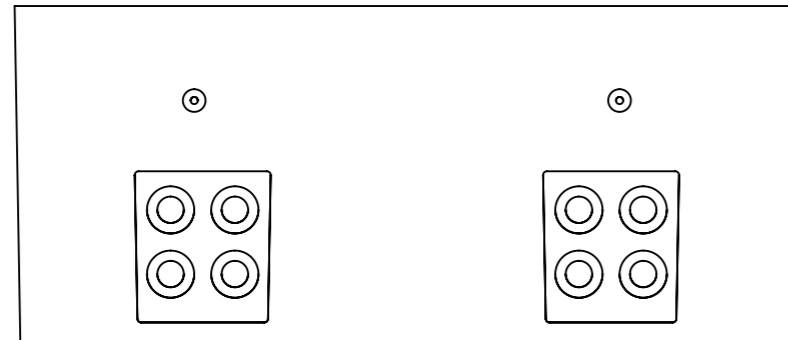

FACE 1

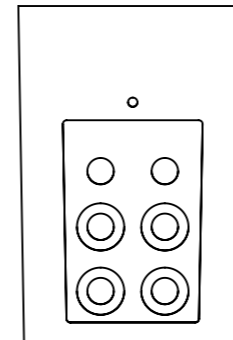

FACE 2

UNCONTROLLED DOCUMENT WHEN PRINTED

- TOLERANCE NOTES:**
1. CONCRETE TOLERANCES TO BE IN CONJUNCTION / ACCORDANCE WITH AS3600 - CONCRETE STRUCTURES
  2. WHEN A BROOME FINISH IS REQUIRED THE GENERAL TOLERANCE SUPERCEEDS THE FLATNESS TOLERANCE
  3. WALL THICKNESS - DIMENSION AS NOTED IS MINIMUM THICKNESS ONLY
  4. CONCRETE GRADE - 40MPA UNLESS NOTED OTHERWISE
  5. DIMENSIONS ARE NOT INCLUSIVE OF SEALANTS OF JOINTS
  6. SURFACE FINISH - CLASS 4 (AS3610.1)

| Rev | DESCRIPTION          | DATE | BY | APPROVED |
|-----|----------------------|------|----|----------|
| 3   |                      |      |    |          |
| 2   |                      |      |    |          |
| 1   | UPDATE DRAWING VIEWS |      |    |          |

| GENERAL TOLERANCES |              | REVISION CONTROL                     |   |
|--------------------|--------------|--------------------------------------|---|
| NOMINAL:           | UP TO 1000mm | 1M AND ABOVE                         | FLATNESS: (NOT INCLUDING BROOME FINISH) |
| TOLERANCE:         | ±5mm         | 1mm IN 200mm UP TO A MAXIMUM OF 20mm | ±4mm PER 1M WIDTH IN 1M LENGTH          |

|                                   |
|-----------------------------------|
| CHK / APPR:<br>PA                 |
| DATE:<br>19/09/2018               |
| RPEQ DOCUMENT #:                  |
| WEIGHT: MIN.700-MAX.900Kg         |
| MATERIAL:<br>CONCRETE FIBRE 40MPA |
| IRF REF:                          |

**Infrastructure Products Australia**  
A CRH COMPANY

HEAD OFFICE:  
1 REEVES COURT  
BREAKWATER, VIC 3219  
1800 065 356

ENGINEERING & DEVELOPMENT:  
91 STRADBROKE STREET  
HEATHWOOD, QLD 4110  
(07) 3714 0444

|   |
|---|
| DRAFTED DATE:<br>9/05/2017                  |
| DRAFTED BY:                                 |
| DATE LAST SAVED:<br>15/07/2022              |
| LAST SAVED BY:<br>NBRADIC                   |
| DRAWN TO AS 1100<br>DO NOT SCALE FROM SHEET |

|  |                                |                  |
|--|--------------------------------|------------------|
| PART/PRODUCT #<br>50201542                     | QUOTE #                        | ORDER #          |
| REINFORCEMENT COMPUTATION                      | PIT #                          | ITEM TYPE        |
| CLIENT<br>CUBIS SYSTEMS/AUSPITS                | PROJECT DESC<br>CATALOGUE ITEM |                  |
| DRAWING NAME<br>PIT CONCRETE TELSTA C9 CLASS B | DRAWING #<br>50201542-01       | REV.<br><b>A</b> |
| PAGE<br>1 / 1                                  | SHEET SIZE<br>A3               | SCALE<br>1:20    |