

GENERAL NOTE:

1. REFER TO GENERAL TOLERANCES UNO
2. GRADE OF CONCRETE - 40MPA (PRE-CAST COMPONENTS)
3. ALL PRE-CAST LIFTING POINTS TO BE USED WHEN LIFTING
4. MINIMUM STRENGTH OF CONCRETE SHALL BE 25MPA AT THE TIME OF LIFTING (PRE-CAST COMPONENTS)
5. REFER TO ANCON LIFTING ARRANGEMENT PLAN (PRE-CAST COMPONENTS)
6. FOUNDATION MATERIAL & PREPARATION PROCEEDURE REFER TO INSTALLATION GUIDE (ULTIMA CONNECT RANGE™)
7. LADDER OR STEP IRONS CAN BE SUPPLIED AS PER CLIENT REQUIREMENT

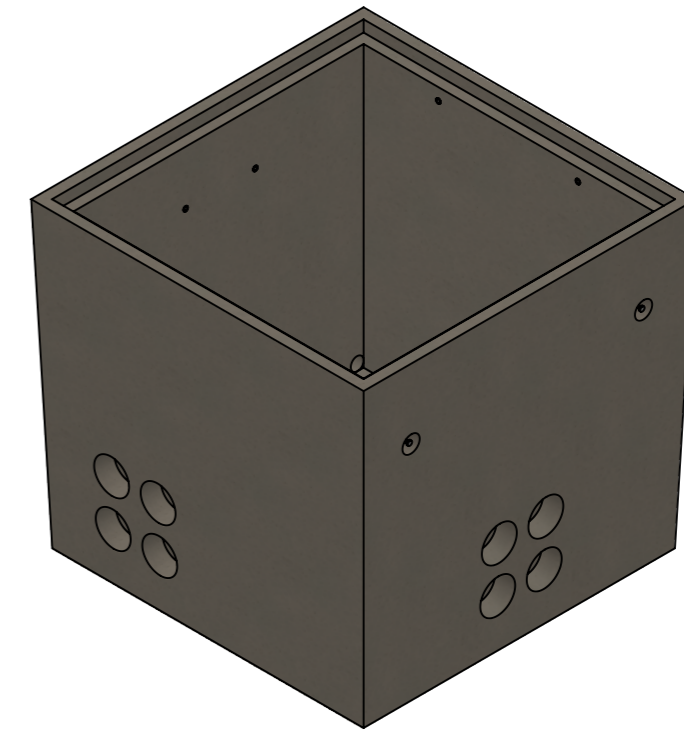

ISOMETRIC VIEW

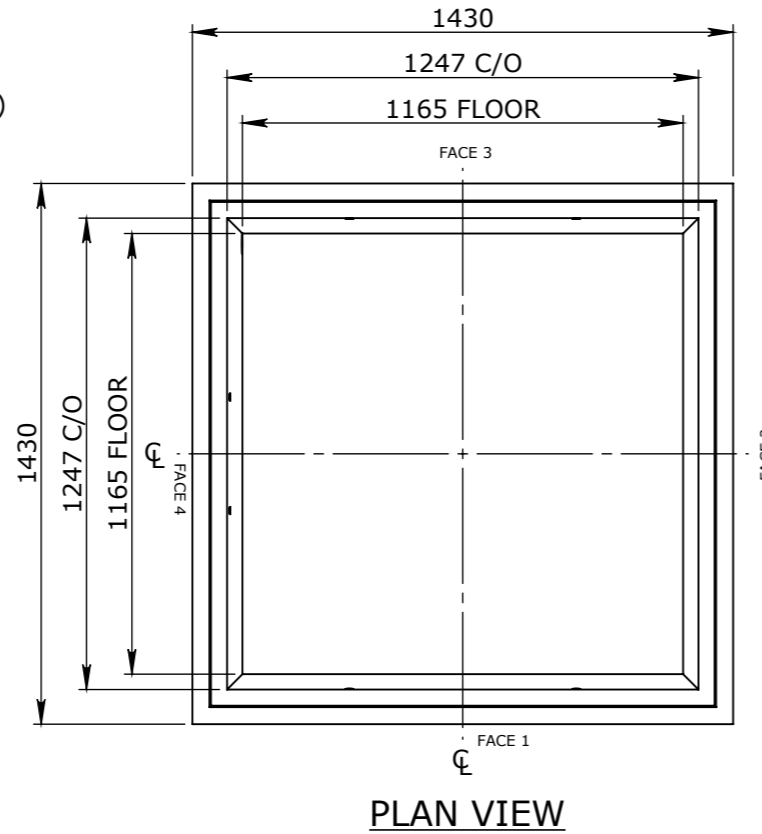
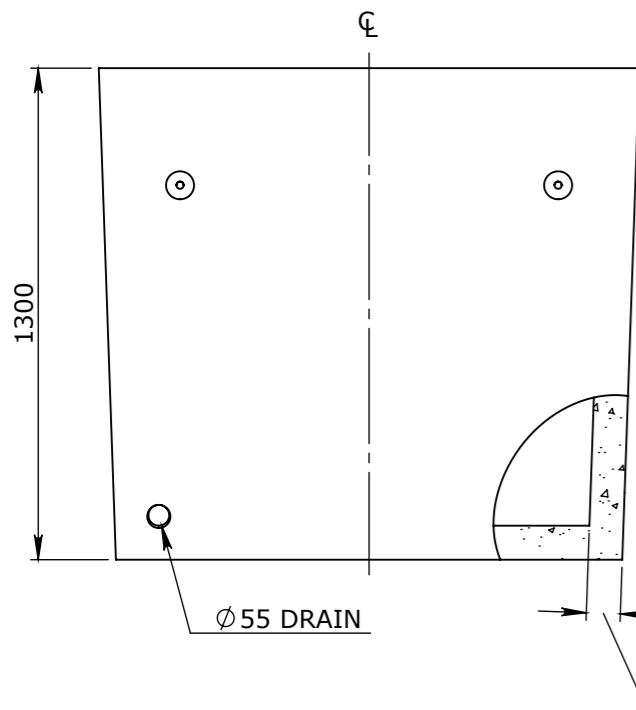

FACE 4

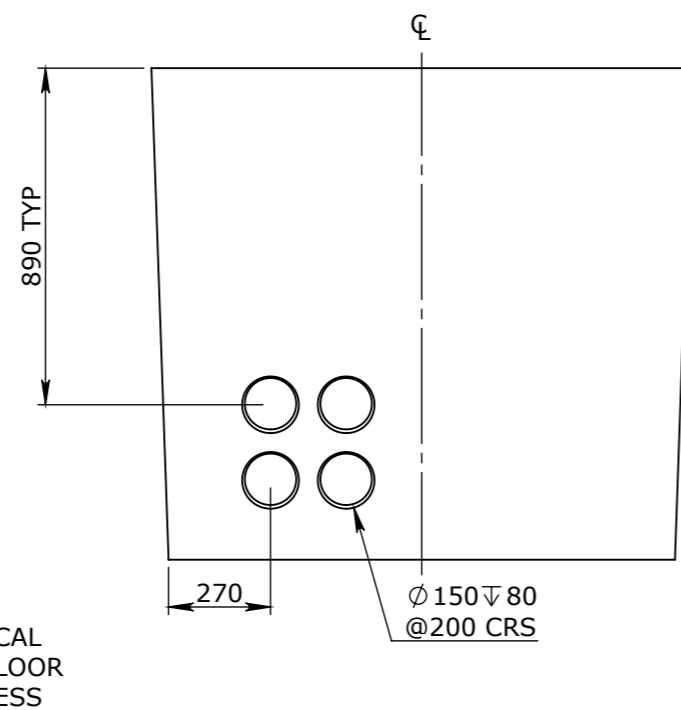

FACE 1

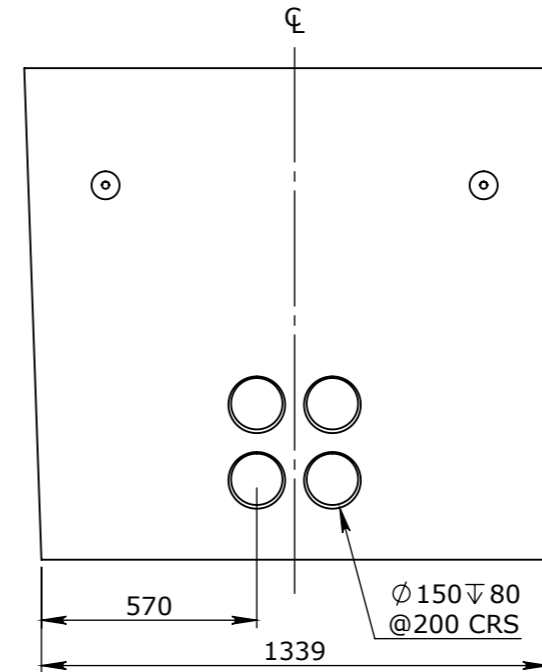

FACE 2

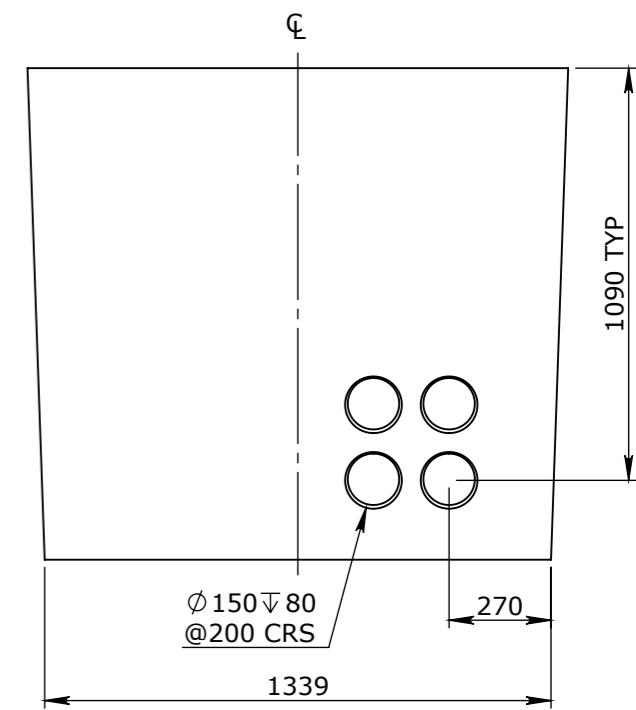

FACE 3

UNCONTROLLED DOCUMENT WHEN PRINTED

TOLERANCE NOTES:

1. CONCRETE TOLERANCES TO BE IN CONJUNCTION / ACCORDANCE WITH AS3600 - CONCRETE STRUCTURES WHEN A BROOME FINISH IS REQUIRED THE GENERAL TOLERANCE SUPERCEEDS THE FLATNESS TOLERANCE
2. WALL THICKNESS - DIMENSION AS NOTED IS MINIMUM THICKNESS ONLY CONCRETE GRADE - 40MPA UNLESS NOTED OTHERWISE
3. DIMENSIONS ARE NOT INCLUSIVE OF SEALANTS OF JOINTS
4. SURFACE FINISH - CLASS 4 (AS3610.1)

Rev	DESCRIPTION	DATE:	BY:	ECO#:
GENERAL TOLERANCES				
NOMINAL:	UP TO 1000mm	1M AND ABOVE		FLATNESS: (NOT INCLUDING BROOME FINISH)
TOLERANCE:	±5mm	1mm IN 200mm UP TO A MAXIMUM OF 20mm		±4mm PER 1M WIDTH IN 1M LENGTH

CHK / APPR:	
DATE:	
RPEQ DOCUMENT #:	
WEIGHT:	1719.29Kg
MATERIAL:	CONCRETE FIBRE 40MPA
SURFACE TREATMENT:	

HEAD OFFICE:
CARNINGHAM ROAD
BALLARAT, VIC 3351
(03) 5335 8741

ENGINEERING & DEVELOPMENT:
2 STRADBROKE STREET
HEATHWOOD, QLD 4110
(07) 3714 0444

THE INFORMATION DISCLOSED IN THIS DOCUMENT IS CONFIDENTIAL AND IS NOT WITHOUT THE EXPRESS CONSENT OF CUBIS SYSTEMS AUSTRALIA TO BE COPIED, REPRODUCED, OR GIVEN TO ANY OTHER PARTY IN ANY FORM AND THAT ALL COPYRIGHT, DESIGNS AND PATENTS VEST IN CUBIS SYSTEMS AUS.

PROJECT DESCRIPTION: CUBIS SYSTEMS AUSTRALIA CATALOGUE PRODUCTS				
DRAWING NAME: PIT CONCRETE 1200x1200x1200x95mm CLASS D				
DRAWN TO AS 1100 DO NOT SCALE FROM SHEET	DRAWING No: 50201521	REV: A		
SHEET: A3	PAGE: 1/1	SCALE UNO: 1:20	DRAFTED DATE: 1/12/2015	DRAFTED BY: Y.J.SHAN