

NOTE:

1. REMOVE ALL BURRS AND SHARP EDGES
2. MATERIAL: SG CAST IRON GRADE 500/320/7 TO AS1831
3. CAST SURFACES PAINTED COLOR BLACK USING SOLVENT BASED ACID ETCH SUPER ETCH PRIMER. WATTYLE 239-MCRFC OR EQUIVALENT.

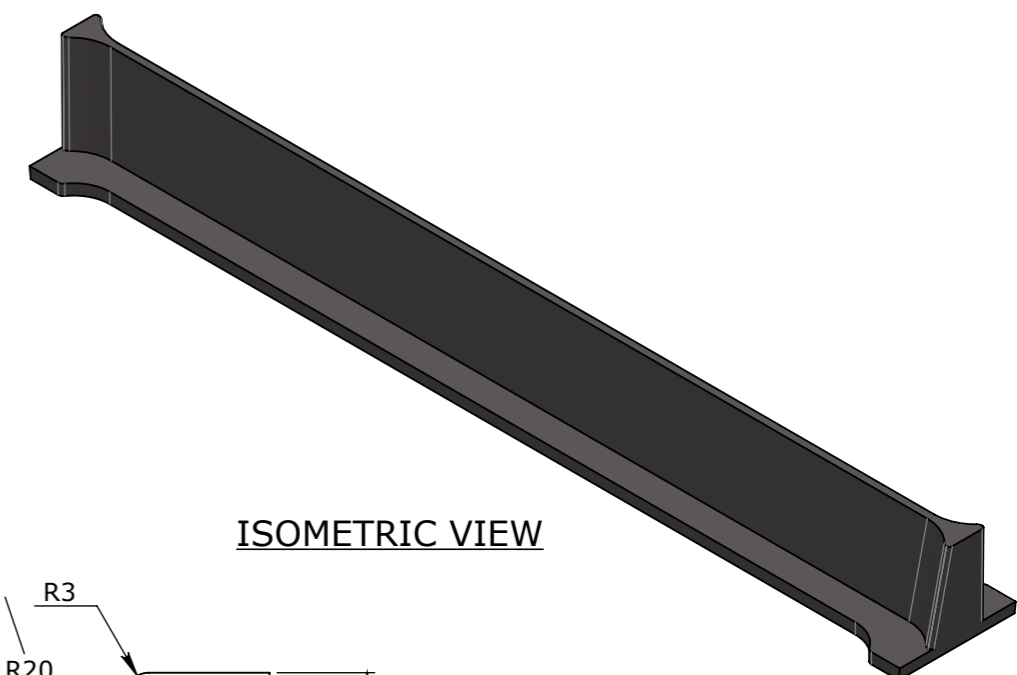

ISOMETRIC VIEW

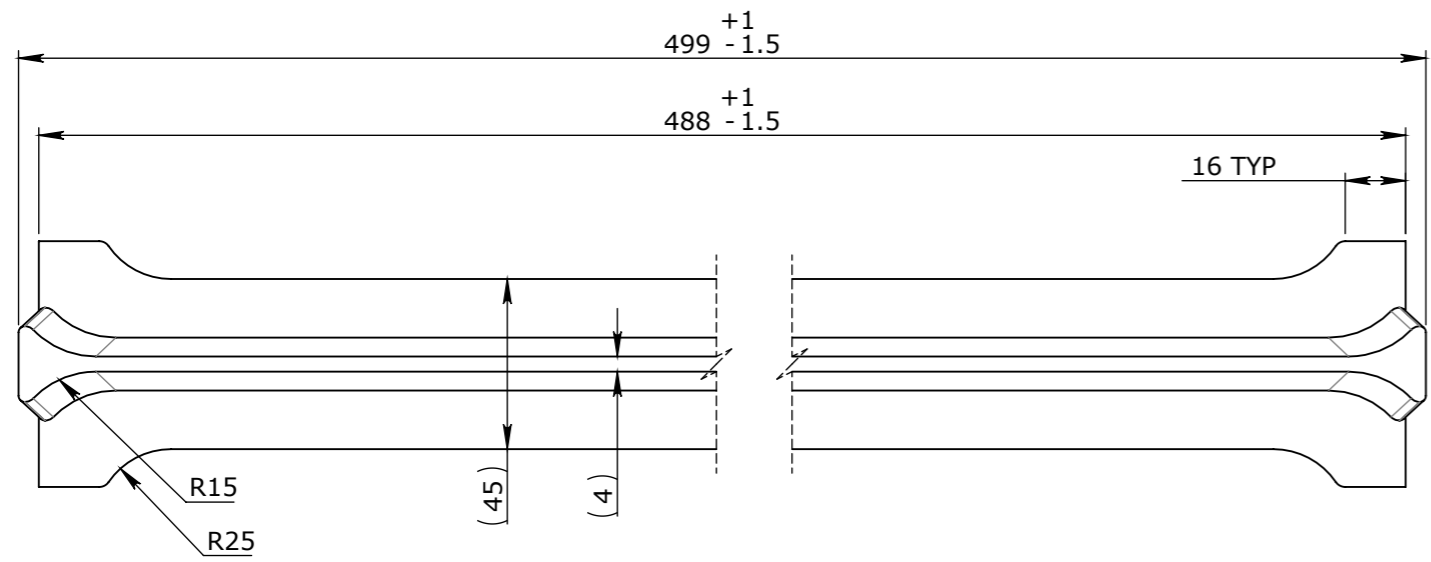

PLAN VIEW

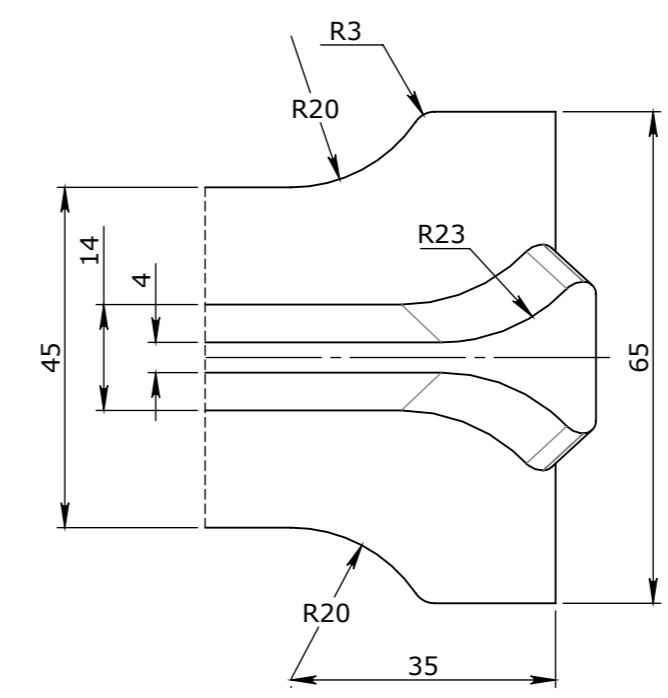

END DETAIL VIEW
SCALE 1:1

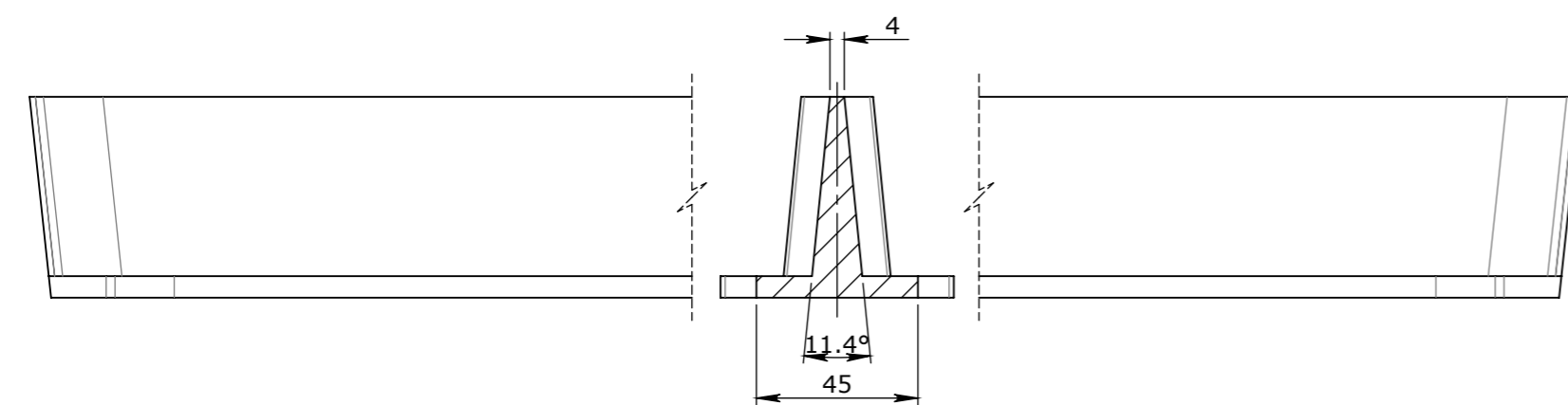

ELEVATION VIEW

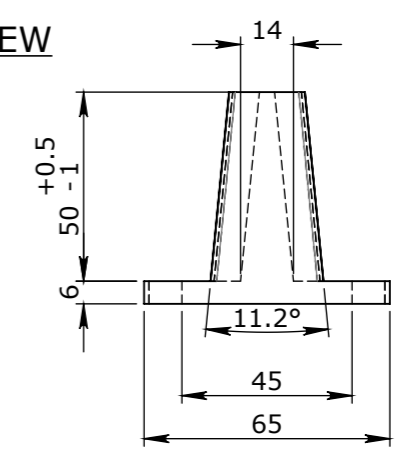

END VIEW

UNCONTROLLED DOCUMENT WHEN PRINTED

1. MATERIAL SPECIFICATIONS UNO			
SECTIONS & FLATS - AS 3679 - GR 300+			
PLATES AS 3678 - GR 250			
SHS AS 1163 - GR 350			
2. WELDING TO COMPLY TO AS 1554.1 UNO			

Rev	DESCRIPTION	DATE:	BY:	ECO#:

GENERAL TOLERANCES				
NOMINAL SIZE	UP TO 150	ABOVE 150 UP TO 500	ABOVE 500	ANGULAR $\angle X.X \pm 0^{\circ}30'$
TOL	± 1.0	± 2.0	± 5.0	$\angle X \pm 1^{\circ}$

TOLERANCES - FABRICATION		
LINEAR X.XX ± 0.02	FACES SQUARE $\perp 0.05/100$	ANGULAR $\angle X.X \pm 0^{\circ}30'$ DIA. CONC WITHIN $\odot 0.05$ TIR
LINEAR X.X ± 0.1	FACES PARALLEL $\parallel 0.05/100$	ANGULAR $\angle X \pm 1^{\circ}$ EDGES CHAMFERED 1.0 x 45 $^{\circ}$
LINEAR X. ± 0.25	FACES FLAT $\nabla 0.05/100$	GENERAL SURFACE FINISH Ra $\sqrt{3.2}$

REVISION CONTROL		

CHK / APPR:	
DATE:	
RPEQ DOCUMENT #:	
WEIGHT:	2.68Kg
MATERIAL:	CAST IRON
SURFACE TREATMENT:	



HEAD OFFICE:
CARNGHAM ROAD
BALLARAT, VIC 3351
(03) 5335 8741

ENGINEERING & DEVELOPMENT:
2 STRADBROKE STREET
HEATHWOOD, QLD 4110
(07) 3714 0444

THE INFORMATION DISCLOSED IN THIS DOCUMENT IS CONFIDENTIAL AND IS NOT WITHOUT THE EXPRESS CONSENT OF CUBIS SYSTEMS AUSTRALIA TO BE COPIED, REPRODUCED, OR GIVEN TO ANY OTHER PARTY IN ANY FORM AND THAT ALL COPYRIGHT, DESIGNS AND PATENTS VEST IN CUBIS SYSTEMS AUS.

PROJECT DESCRIPTION: CUBIS SYSTEMS AUSTRALIA CATALOGUE PRODUCTS				
DRAWING NAME: CROSSBAR TO SUIT P6 PIT				
DRAWN TO AS 1100 DO NOT SCALE FROM SHEET	DRAWING No: 50201264	REV: A		
SHEET: A3	PAGE: 1/1	SCALE UNO: 1:2	DRAFTED DATE: 28/09/2015	DRAFTED BY: