

CONCRETE NOTE:

1. REFER TO GENERAL TOLERANCES UNO
2. GRADE OF CONCRETE - 40MPa
3. ALL LIFTING POINTS TO BE USED WHEN LIFTING
4. MINIMUM STRENGTH OF CONCRETE SHALL BE 25MPa AT THE TIME OF LIFTING
5. REFER TO PRECAST CONCRETE INSTALLATION GUIDE V.1 2019 FOR INSTALLATION DETAILS
6. REFER TO ANCON LIFTING ARRANGEMENT PLAN

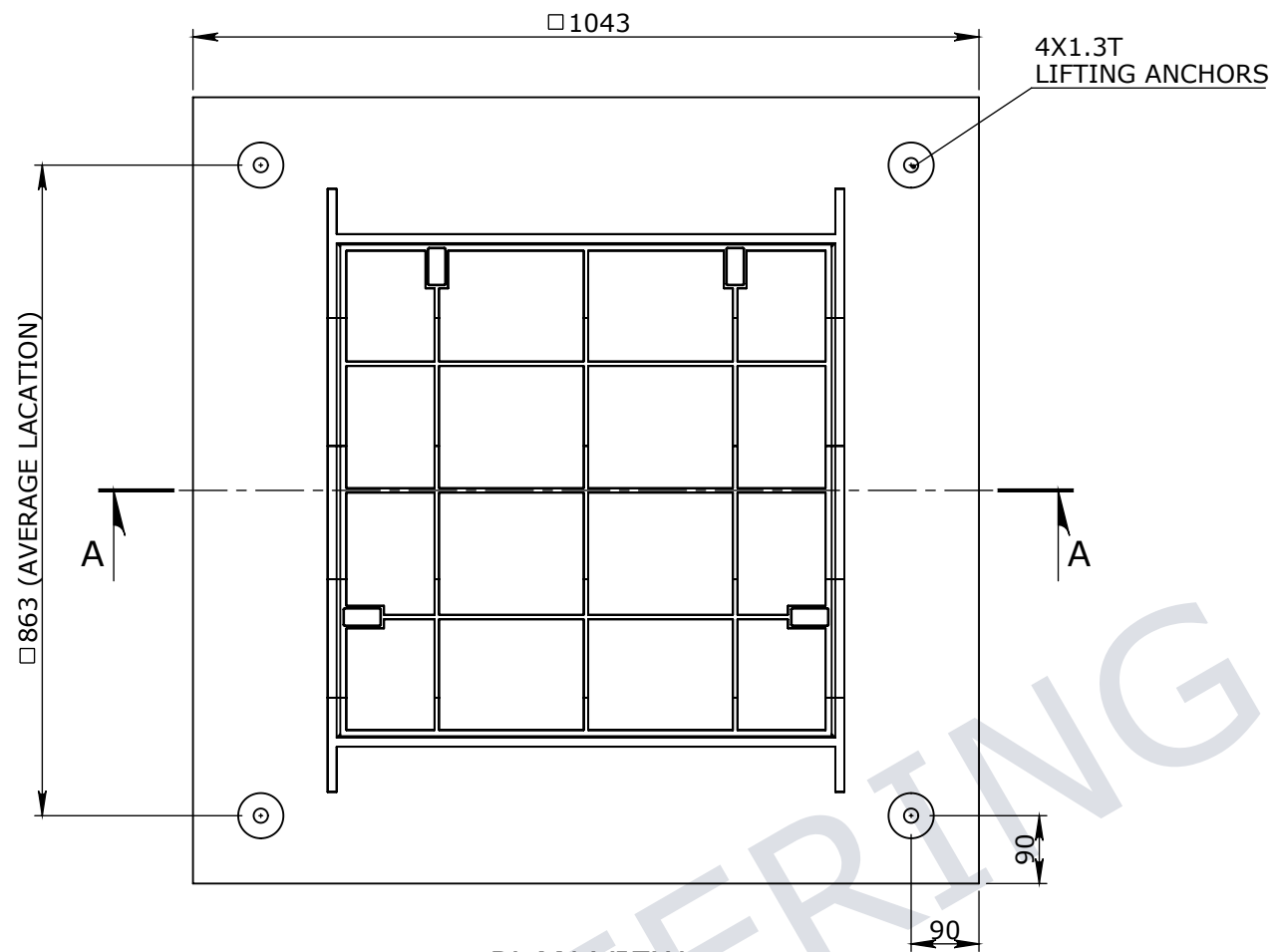

PLAN VIEW

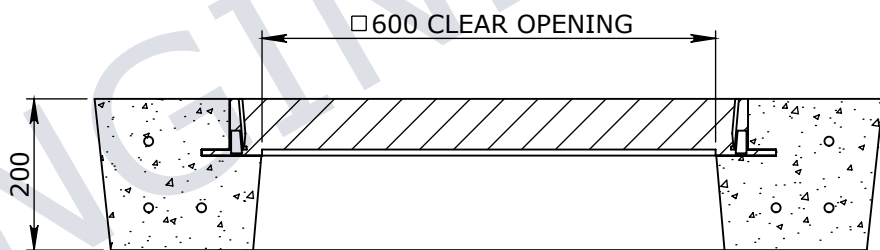

SECTION A-A

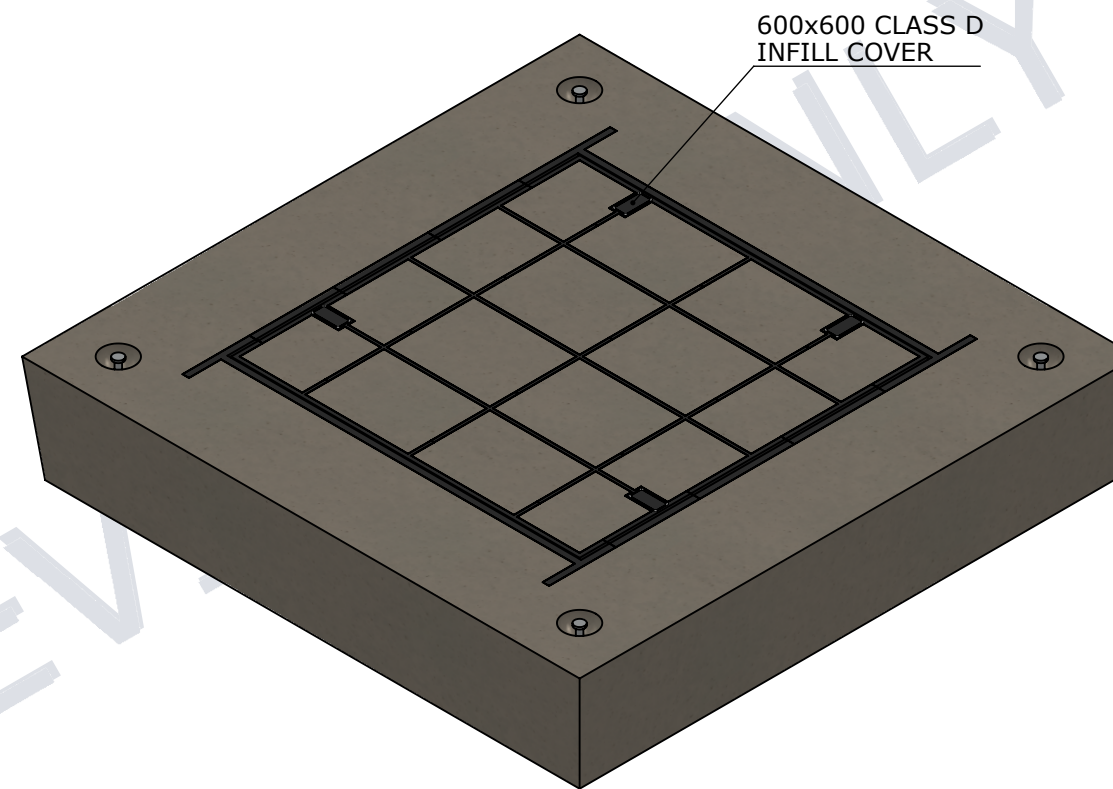

ISOMETRIC VIEW

UNCONTROLLED DOCUMENT WHEN PRINTED

- TOLERANCE NOTES:**
1. CONCRETE TOLERANCES TO BE IN CONJUNCTION / ACCORDANCE WITH AS3600 - CONCRETE STRUCTURES WHEN A BROOME FINISH IS REQUIRED THE GENERAL TOLERANCE SUPERCEDES THE FLATNESS TOLERANCE
 2. WALL THICKNESS - DIMENSION AS NOTED IS MINIMUM THICKNESS ONLY CONCRETE GRADE - 40MPa UNLESS NOTED OTHERWISE
 3. DIMENSIONS ARE NOT INCLUSIVE OF SEALANTS OF JOINTS
 4. SURFACE FINISH - CLASS 4 (AS3610.1)

Rev	DESCRIPTION	DATE	BY	ECO#

GENERAL TOLERANCES		REVISION CONTROL	
NOMINAL:	UP TO 1000mm	1M AND ABOVE	FLATNESS: (NOT INCLUDING BROOME FINISH)
TOLERANCE:	±5mm	1mm IN 200mm UP TO A MAXIMUM OF 20mm	±4mm PER 1M WIDTH IN 1M LENGTH

CHK / APPR:	
DATE:	
RPEQ DOCUMENT #:	
WEIGHT:	446.21Kg
MATERIAL:	CONCRETE 40MPa
SURFACE TREATMENT:	

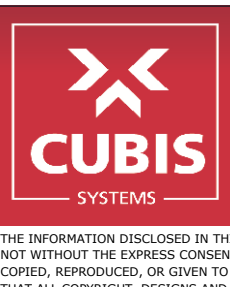

HEAD OFFICE:
CARNINGHAM ROAD
BALLARAT, VIC 3351
(03) 5335 8741

ENGINEERING & DEVELOPMENT:
2 STRADBROKE STREET
HEATHWOOD, QLD 4110
(07) 3714 0444

PROJECT DESCRIPTION:				
CUBIS SYSTEMS AUSTRALIA CATALOGUE PRODUCTS				
DRAWING NAME: ENCASEMENT 1000x1000x200 with 66D INFILL CLASS D				
DRAWN TO AS 1100 DO NOT SCALE FROM SHEET	DRAWING No: 50201259	REV: A		
SHEET: A3	PAGE: 1/1	SCALE UNO: 1:10	DRAFTED DATE: 2/01/2020	DRAFTED BY:

THE INFORMATION DISCLOSED IN THIS DOCUMENT IS CONFIDENTIAL AND IS NOT WITHOUT THE EXPRESS CONSENT OF CUBIS SYSTEMS AUSTRALIA TO BE COPIED, REPRODUCED, OR GIVEN TO ANY OTHER PARTY IN ANY FORM AND THAT ALL COPYRIGHT, DESIGNS AND PATENTS VEST IN CUBIS SYSTEMS AUS.