

BILL OF MATERIALS - 50201212

ITEM #	QTY.	PART #	EPICORE DESCRIPTION
1	1	50201211-01	RAILduct™ ASSEMBLY STRAIGHT BLACK - BASE
2	1	50201211-02	RAILduct™ ASSEMBLY STRAIGHT BLACK - COVER
3	1	50201211-03	RAILduct™ ASSEMBLY STRAIGHT BLACK - DIVIDER

NOTE;
WHEN INTERLOCKED AS UNIT EACH ITEM REPRESENTS A 1m SECTION

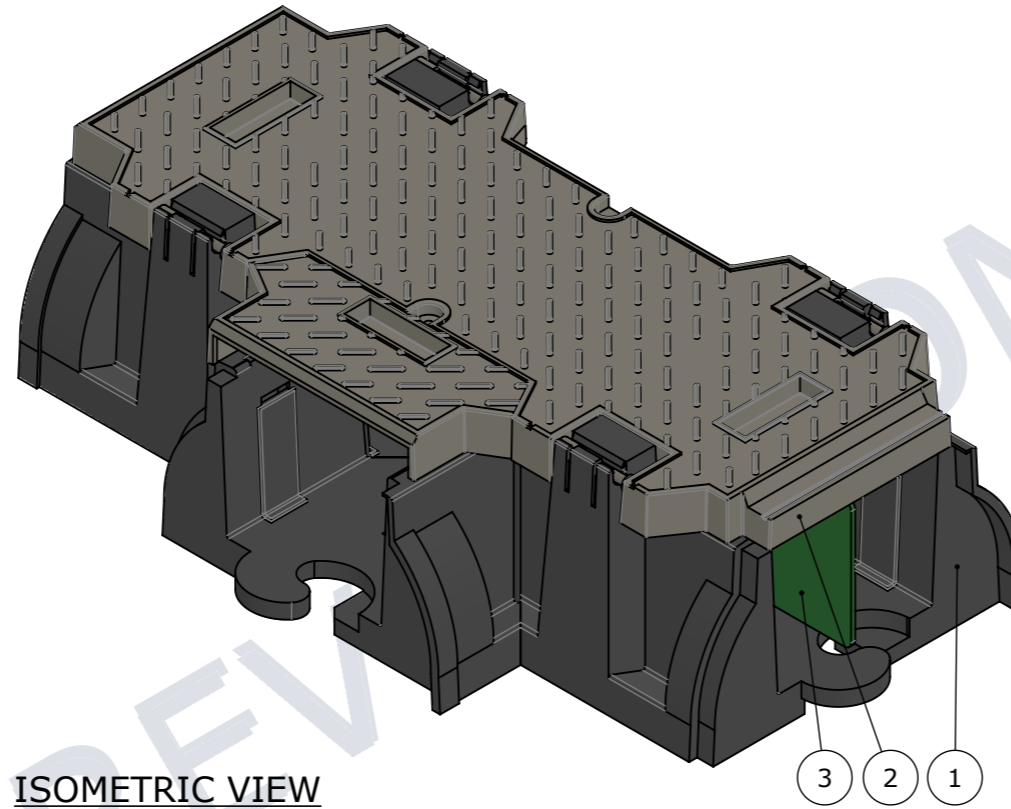

ISOMETRIC VIEW

SHOWN WITH OPTIONAL DIVIDER
COLOURS CHANGED FOR CLARITY

UNCONTROLLED DOCUMENT WHEN PRINTED

- 1. MATERIAL SPECIFICATIONS UNO SECTIONS & FLATS - AS 3679 - GR 300+ PLATES AS 3678 - GR 250 SHS AS 1163 - GR 350
- 2. WELDING TO COMPLY TO AS 1554.1 UNO

Rev	DESCRIPTION	DATE:	BY:	ECO#:

CHK / APPR: _____
DATE: _____
RPEQ DOCUMENT #: _____



HEAD OFFICE:
CARNNGHAM ROAD
BALLARAT, VIC 3351
(03) 5335 8741

ENGINEERING & DEVELOPMENT:
2 STRADBROKE STREET
HEATHWOOD, QLD 4110
(07) 3714 0444

PROJECT DESCRIPTION:
CUBIS SYSTEMS AUSTRALIA CATALOGUE PRODUCTS

DRAWING NAME:
RAILDUCT T-PIECE RIGHT ASSEMBLY

GENERAL TOLERANCES				
NOMINAL SIZE	UP TO 150	ABOVE 150 UP TO 500	ABOVE 500	ANGULAR ∠ X.X±0°30'
TOL	±1.0	±2.0	±5.0	∠ X ± 1°

TOLERANCES - FABRICATION			REVISION CONTROL	
LINEAR X.XX ± 0.02	FACES SQUARE ⊥ 0.05/100	ANGULAR ∠ X.X ± 0°30' DIA. CONC WITHIN Ⓞ 0.05 TIR		
LINEAR X.X ± 0.1	FACES PARALLEL // 0.05/100	ANGULAR ∠ X ± 1° EDGES CHAMFERED 1.0 x 45°		
LINEAR X. ± 0.25	FACES FLAT ▱ 0.05/100	GENERAL SURFACE FINISH Ra ^{3.2} √		

WEIGHT: **15.11Kg**

MATERIAL: **STRUCTURAL FOAM, HDPE**

SURFACE TREATMENT: _____

THE INFORMATION DISCLOSED IN THIS DOCUMENT IS CONFIDENTIAL AND IS NOT WITHOUT THE EXPRESS CONSENT OF CUBIS SYSTEMS AUSTRALIA TO BE COPIED, REPRODUCED, OR GIVEN TO ANY OTHER PARTY IN ANY FORM AND THAT ALL COPYRIGHT, DESIGNS AND PATENTS VEST IN CUBIS SYSTEMS AUS.

 DRAWN TO AS 1100 DO NOT SCALE FROM SHEET	DRAWING No: 50201216	REV: A
SHEET: A3	PAGE: 1/2	SCALE UNO: 1:5
DRAFTED DATE: 13/04/2016	DRAFTED BY: _____	

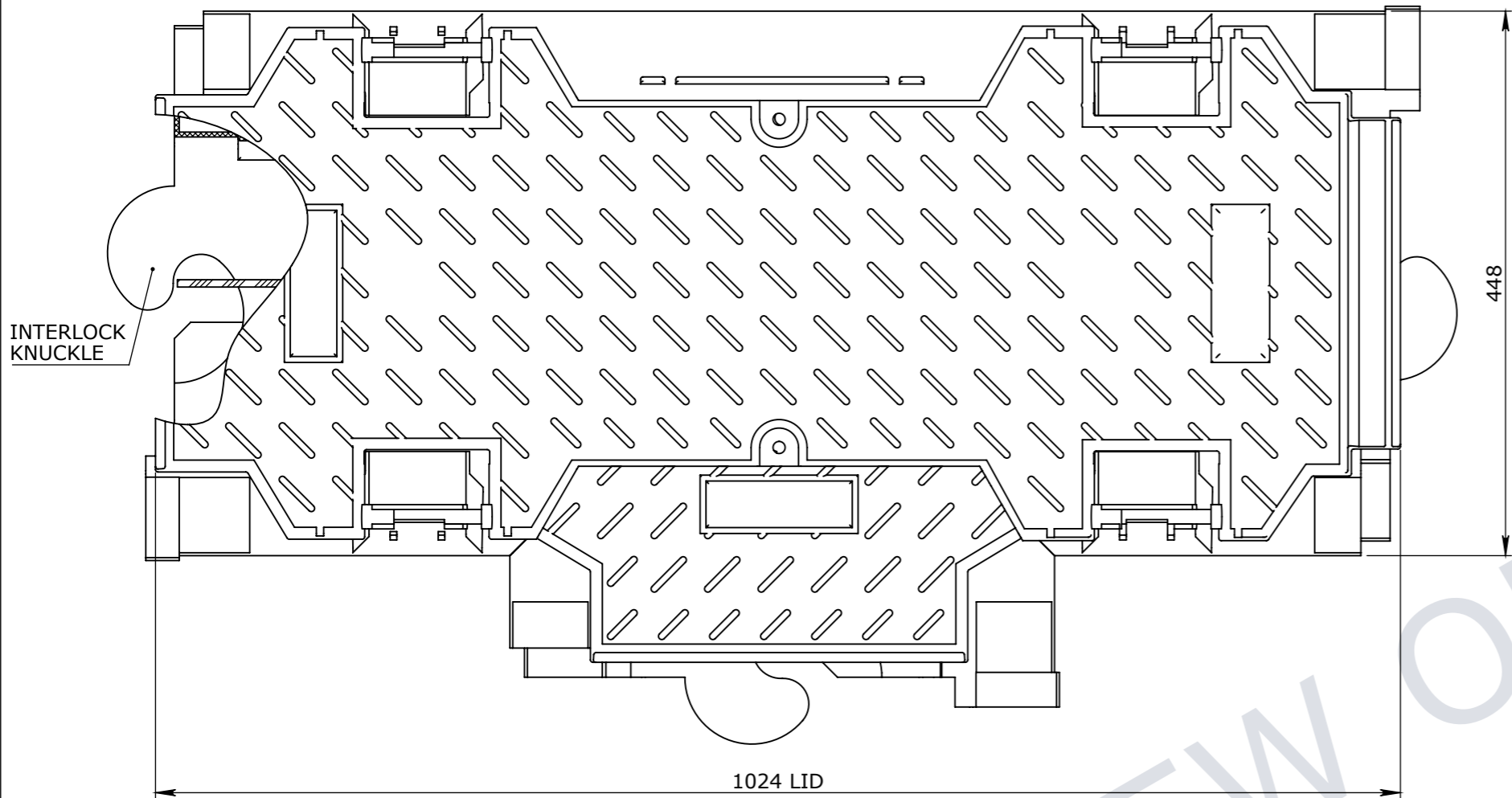

PLAN VIEW

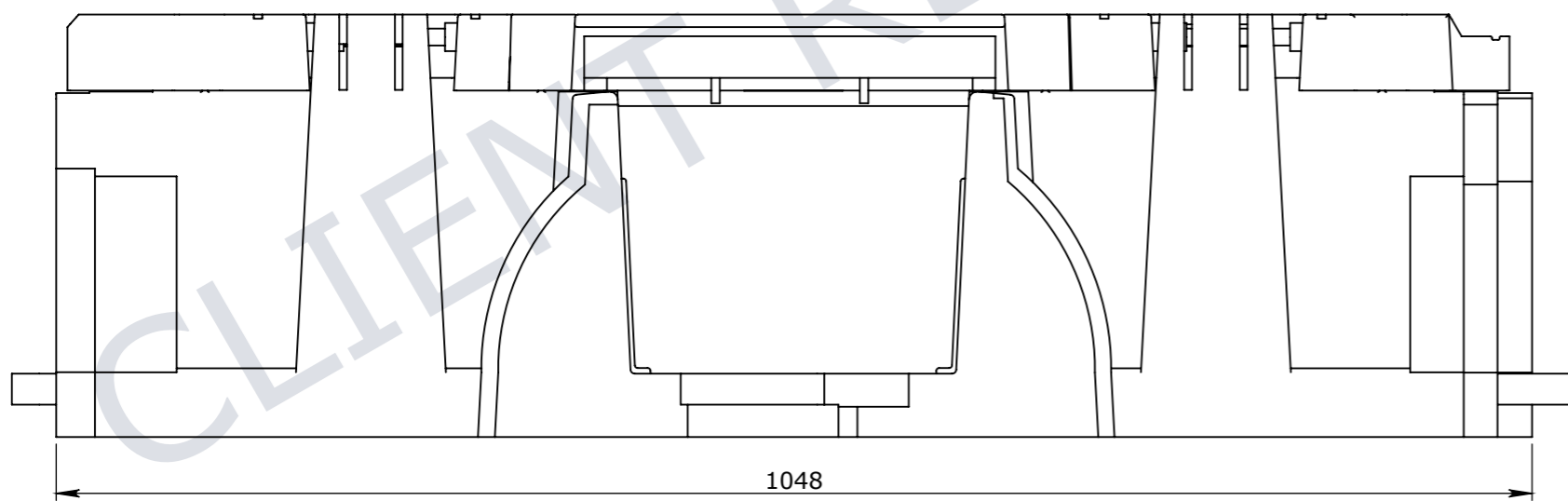

ELEVATION VIEW

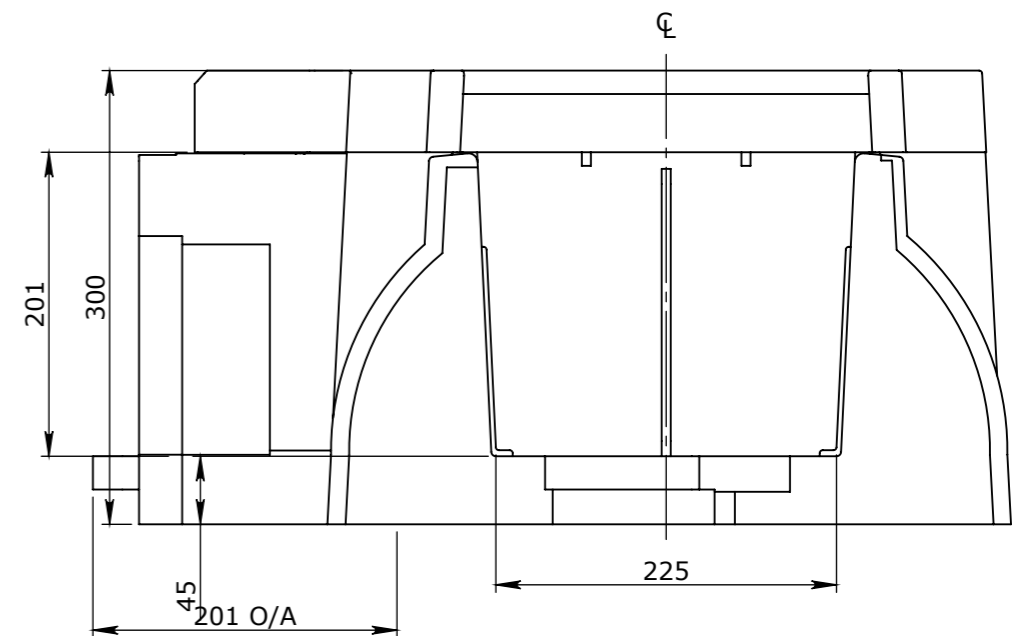

END VIEW

UNCONTROLLED DOCUMENT WHEN PRINTED



VICTORIA:
CARNHAM ROAD
BALLARAT, VIC 3351
QLD:
91 STRADBROKE STREET
HEATHWOOD, QLD 4110
DRAWN TO AS 1100
DO NOT SCALE
FROM SHEET

NAME:
RAILDUCT T-PIECE RIGHT ASSEMBLY
DRAWING No:
50201216
DRAFTED BY:
A. CHAO

REV
A
SCALE UNO:
1:5

DRAFTED DATE: PAGE: 2/2 SHEET: A3