

**CONCRETE NOTE:**

1. REFER TO GENERAL TOLERANCES UNO
2. STEEL AND FIBER REINFORCED CONCRETE - 40MPA
3. ALL LIFTING POINTS TO BE USED WHEN LIFTING
4. MINIMUM STRENGTH OF CONCRETE SHALL BE 25MPA AT THE TIME OF LIFTING
5. REFER TO BVC1-INS-C-001 (STD INSTALLATION GUIDE) FOR INSTALLATION DETAILS
6. REFER TO ANCON LIFTING ARRANGEMENT PLAN

BILL OF MATERIALS		
ITEM NO.	QTY.	DESCRIPTION
1	1	CAST PIT
2	2	LOCK BOX
3	4	
4	8	M12x50 FERRULE (ZINC)
5	4	UNISTRUT - P3300

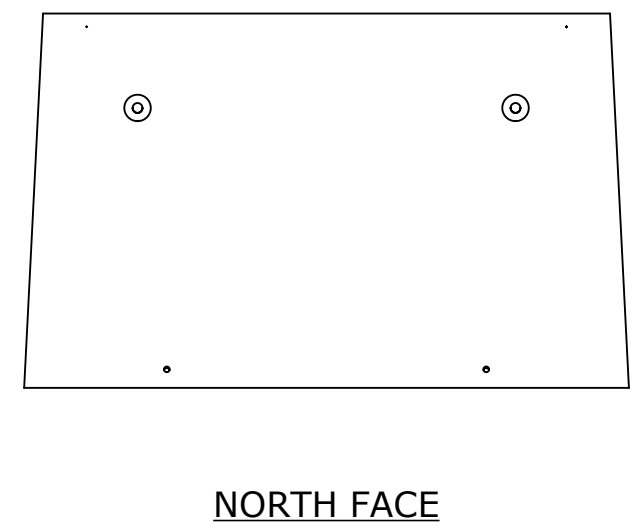
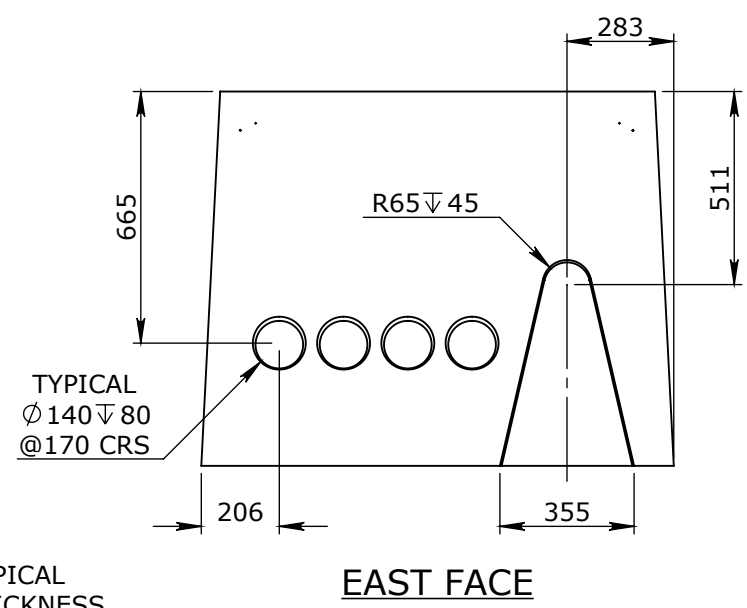
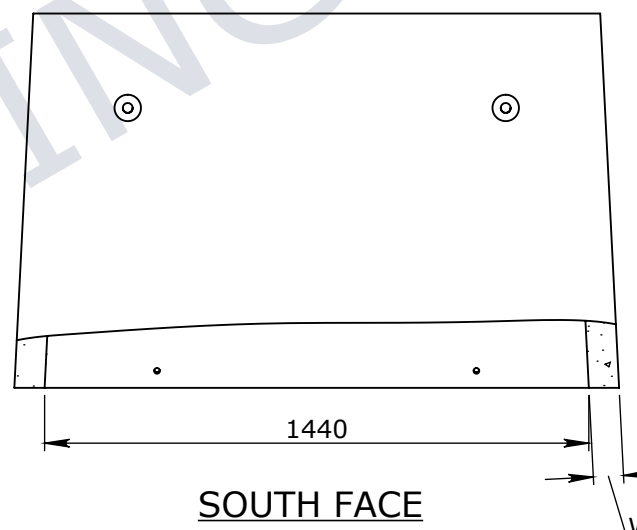
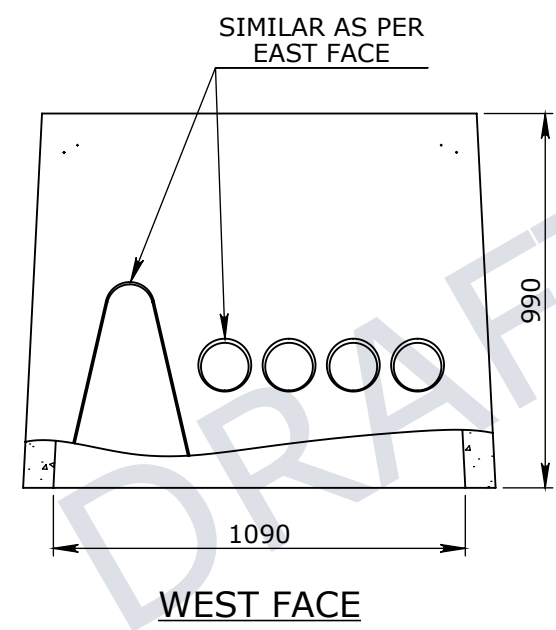
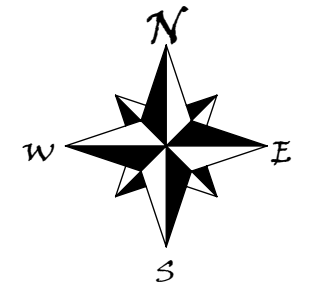
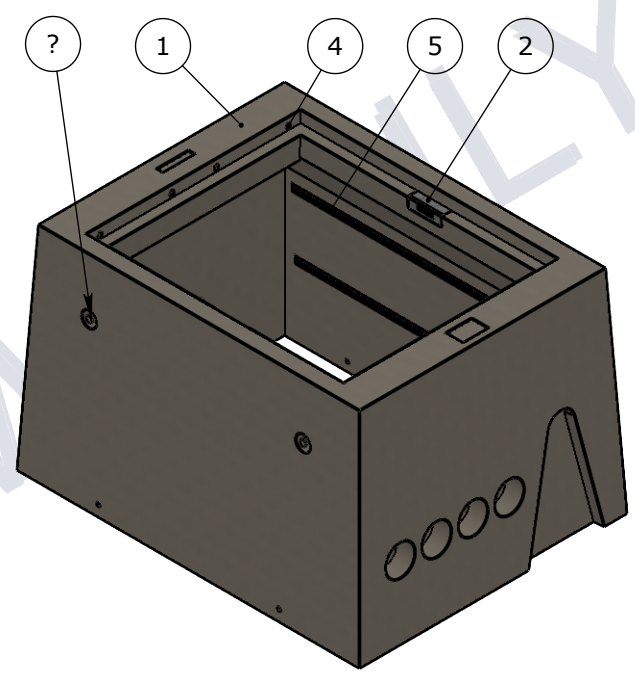
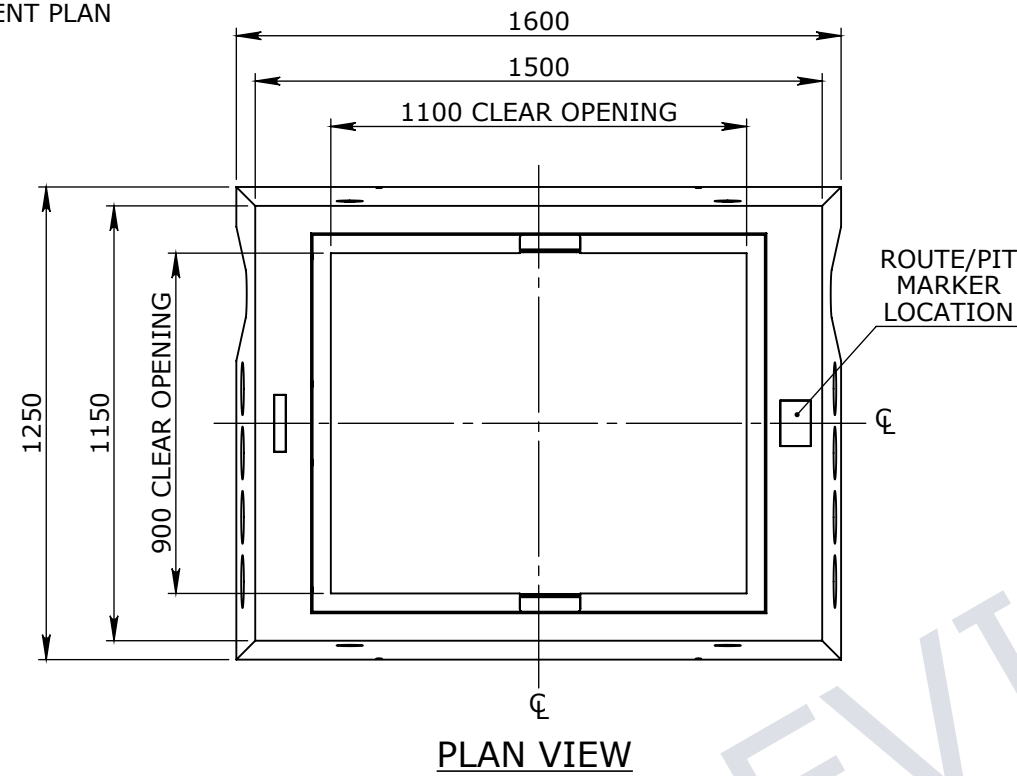

UNCONTROLLED DOCUMENT WHEN PRINTED

**TOLERANCE NOTES:**

1. CONCRETE TOLERANCES TO BE IN CONJUNCTION / ACCORDANCE WITH AS3600 - CONCRETE STRUCTURES WHEN A BROOME FINISH IS REQUIRED THE GENERAL TOLERANCE SUPERCEDES THE FLATNESS TOLERANCE
2. WALL THICKNESS - DIMENSION AS NOTED IS MINIMUM THICKNESS ONLY CONCRETE GRADE - 40MPA UNLESS NOTED OTHERWISE
3. DIMENSIONS ARE NOT INCLUSIVE OF SEALANTS OF JOINTS
4. SURFACE FINISH - CLASS 4 (AS3610.1)

Rev	DESCRIPTION	DATE:	BY:	ECO#:
GENERAL TOLERANCES				
NOMINAL:	UP TO 1000mm	1M AND ABOVE		FLATNESS: (NOT INCLUDING BROOME FINISH)
TOLERANCE:	±5mm	1mm IN 200mm UP TO A MAXIMUM OF 20mm		±4mm PER 1M WIDTH IN 1M LENGTH

CHK / APPR:	
DATE:	
RPEQ DOCUMENT #:	
WEIGHT:	1100Kg
MATERIAL:	CONCRETE 40MPA
SURFACE TREATMENT:	

HEAD OFFICE:  
CARNINGHAM ROAD  
BALLARAT, VIC 3351  
(03) 5335 8741

ENGINEERING & DEVELOPMENT:  
2 STRADBROKE STREET  
HEATHWOOD, QLD 4110  
(07) 3714 0444

THE INFORMATION DISCLOSED IN THIS DOCUMENT IS CONFIDENTIAL AND IS NOT WITHOUT THE EXPRESS CONSENT OF CUBIS SYSTEMS AUSTRALIA TO BE COPIED, REPRODUCED, OR GIVEN TO ANY OTHER PARTY IN ANY FORM AND THAT ALL COPYRIGHT, DESIGNS AND PATENTS VEST IN CUBIS SYSTEMS AUS.

PROJECT DESCRIPTION: <b>CUBIS SYSTEMS AUSTRALIA CATALOGUE PRODUCTS</b>				
DRAWING NAME: PIT CONCRETE C1 CLASS D				
DRAWN TO AS 1100 DO NOT SCALE FROM SHEET	DRAWING No: 50201208-01	REV: <b>B</b>		
SHEET: A3	PAGE: 1/1	SCALE UNO: 1:20	DRAFTED DATE: 2/12/2015	DRAFTED BY: