

PRODUCT NOTE:

1. MATERIAL - STEEL REINFORCED (BMC) BULK MOULDING COMPOUND
2. COLOUR - PMS 414

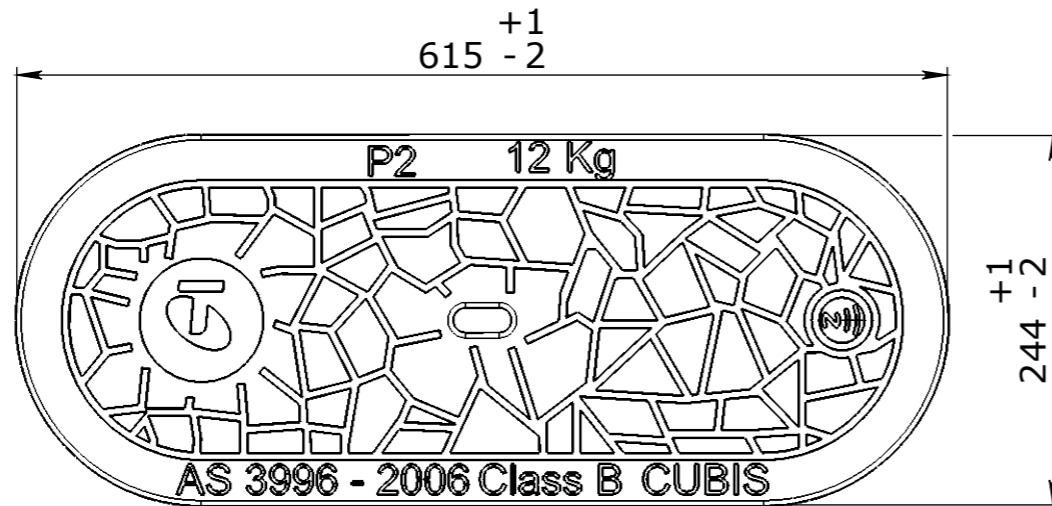

PLAN VIEW

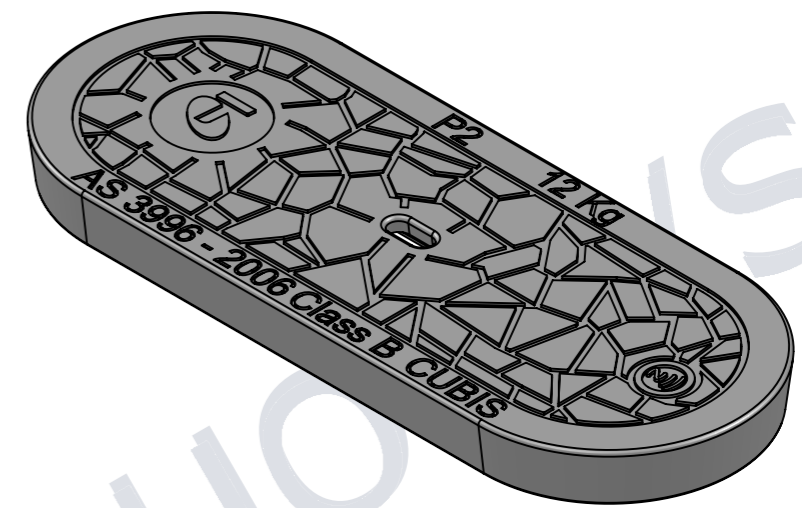

ISOMETRIC VIEW

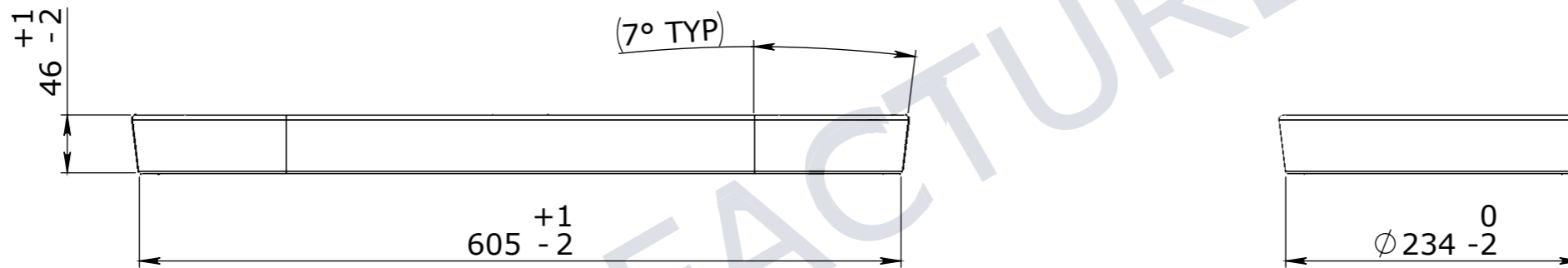

ELEVATION VIEW

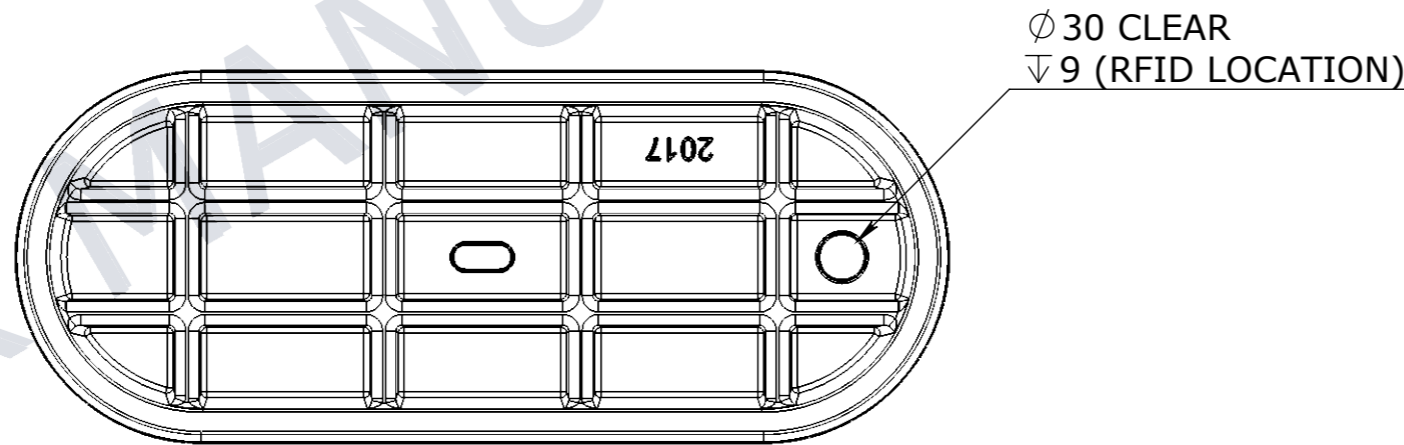

BOTTOM VIEW

UNCONTROLLED DOCUMENT WHEN PRINTED

- TOLERANCE NOTES:**
1. CONCRETE TOLERANCES TO BE IN CONJUNCTION / ACCORDANCE WITH AS3600 - CONCRETE STRUCTURES WHEN A BROOME FINISH IS REQUIRED THE GENERAL TOLERANCE SUPERCEEDS THE FLATNESS TOLERANCE
 2. WALL THICKNESS - DIMENSION AS NOTED IS MINIMUM THICKNESS ONLY
 3. CONCRETE GRADE - 40MPA UNLESS NOTED OTHERWISE
 4. DIMENSIONS ARE NOT INCLUSIVE OF SEALANTS OF JOINTS
 5. SURFACE FINISH - CLASS 4 (AS3610.1)

Rev	DESCRIPTION	DATE	BY	ECO#
1	CORRECTED THE DRAWING DIMENSION ON END VIEW	25/11/20	CA	

GENERAL TOLERANCES		REVISION CONTROL	
NOMINAL:	UP TO 1000mm	1M AND ABOVE	FLATNESS: (NOT INCLUDING BROOME FINISH)
TOLERANCE:	±5mm	1mm IN 200mm UP TO A MAXIMUM OF 20mm	±4mm PER 1M WIDTH IN 1M LENGTH

CHK / APPR:	CA
DATE:	
RPEQ DOCUMENT #:	
WEIGHT:	12Kg
MATERIAL:	BMC
SURFACE TREATMENT:	

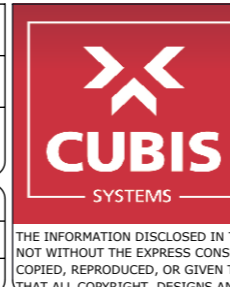

HEAD OFFICE:
CARNINGHAM ROAD
BALLARAT, VIC 3351
(03) 5335 8741

ENGINEERING & DEVELOPMENT:
2 STRADBROKE STREET
HEATHWOOD, QLD 4110
(07) 3714 0444

PROJECT DESCRIPTION:				
CUBIS SYSTEMS AUSTRALIA CATALOGUE PRODUCTS				
DRAWING NAME: AX S™ P2 COVER COMPOSITE SMART TELSTRA CLASS B				
DRAWN TO AS 1100 DO NOT SCALE FROM SHEET		DRAWING No: 50201184		REV: 1
SHEET: A3	PAGE: 1/1	SCALE UNO: 1:5	DRAFTED DATE: 25/05/2018	DRAFTED BY: P.ADAMS