

NOTE:

1. REMOVE ALL BURRS AND SHARP EDGES
2. MATERIAL: SG CAST IRON GRADE 500/320/7 TO AS1831
3. CAST SURFACES PAINTED COLOR BLACK USING SOLVENT BASED ACID ETCH SUPER ETCH PRIMER. WATTYLE 239-MCRCF OR EQUIVALENT. SEE WEBSITE: www.wattyl.com.au

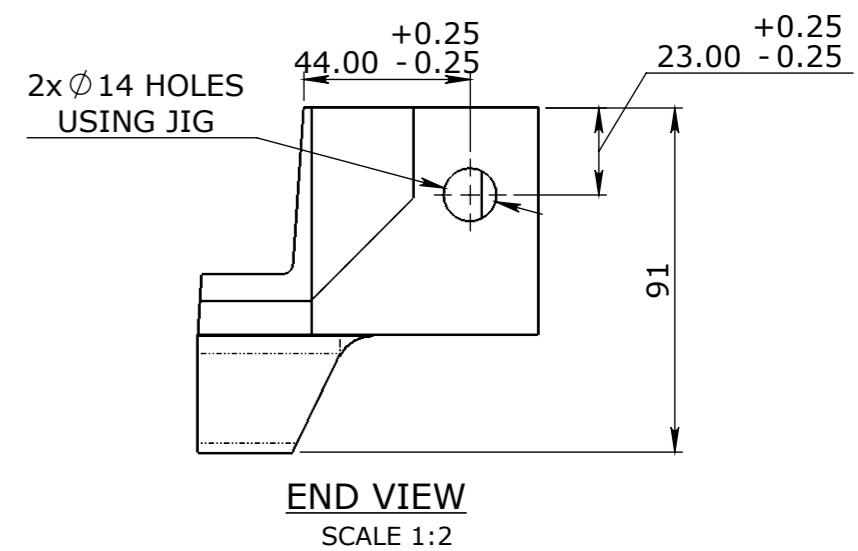
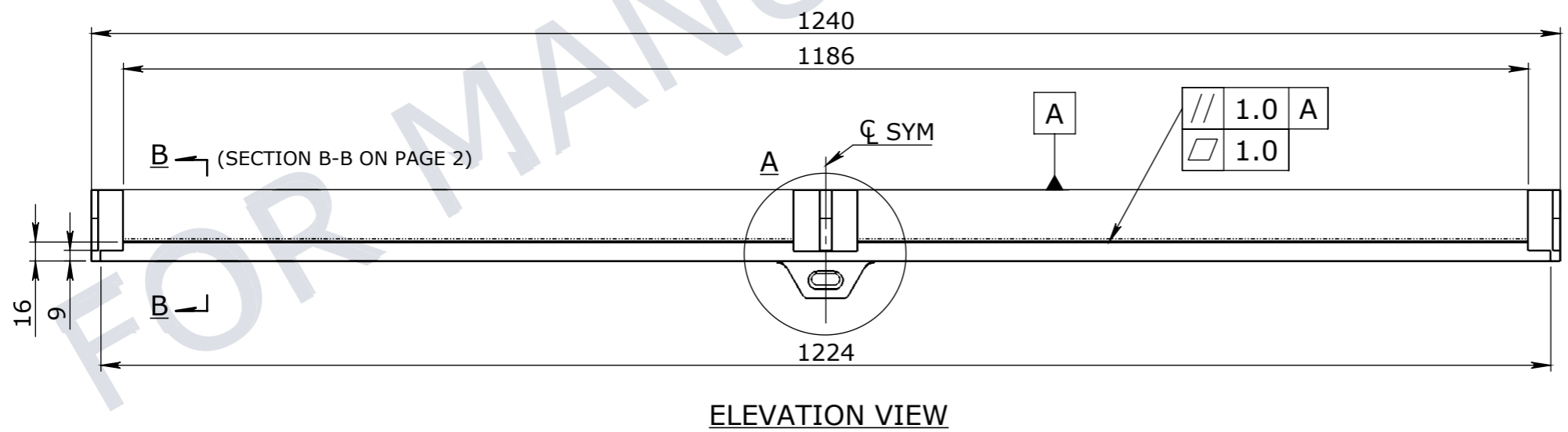
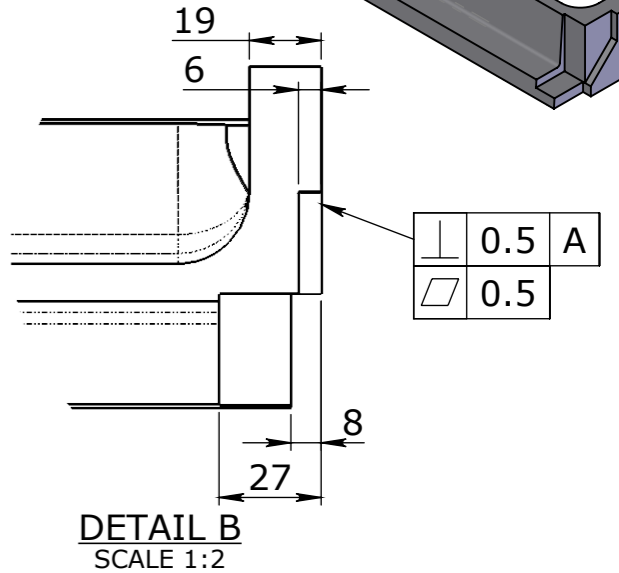
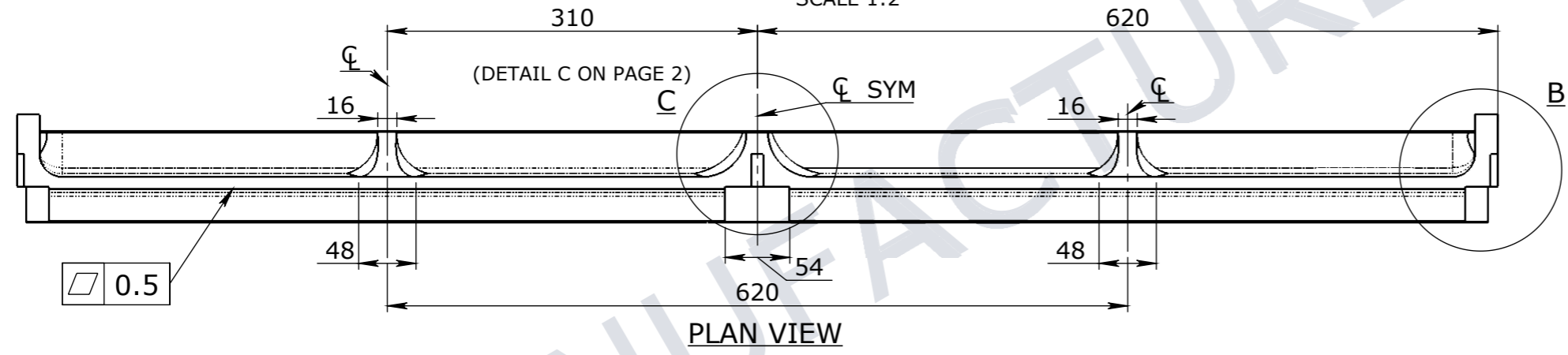
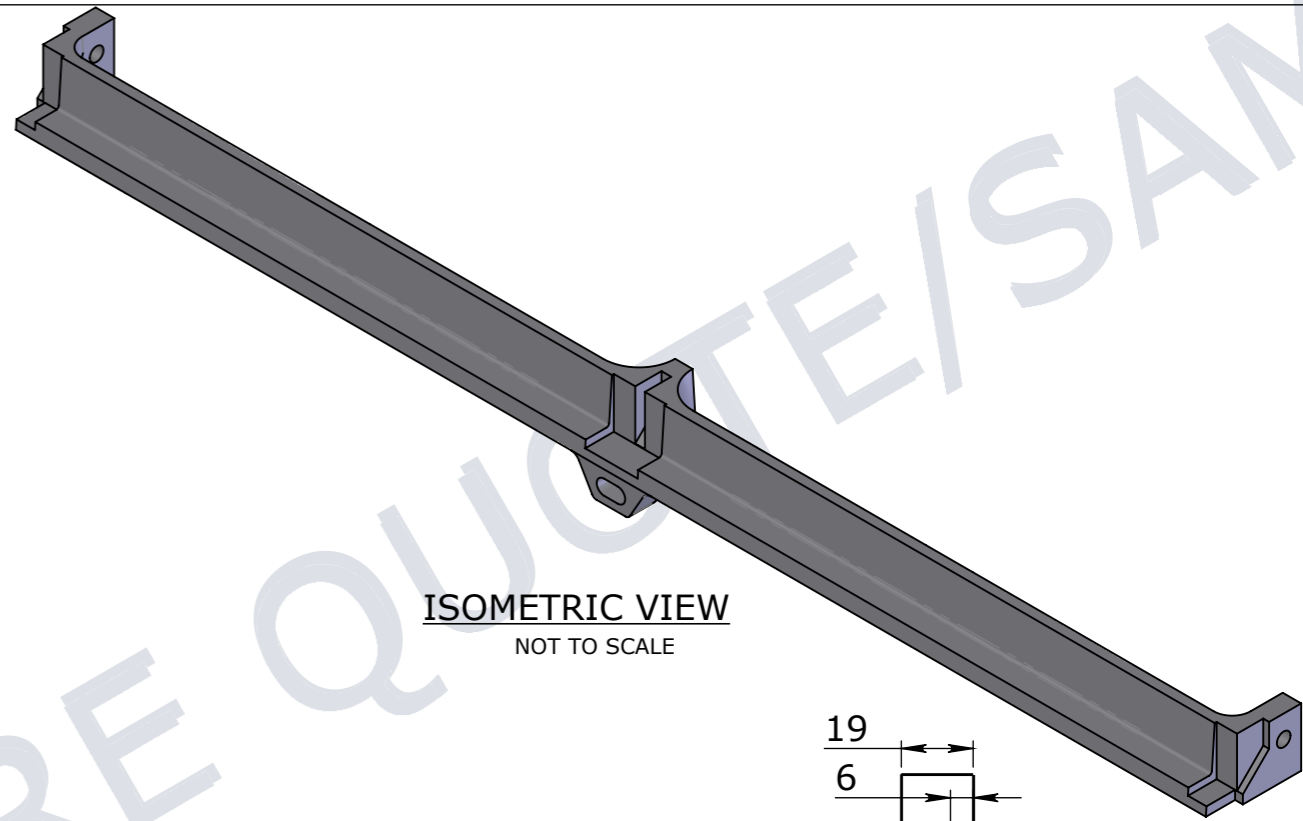
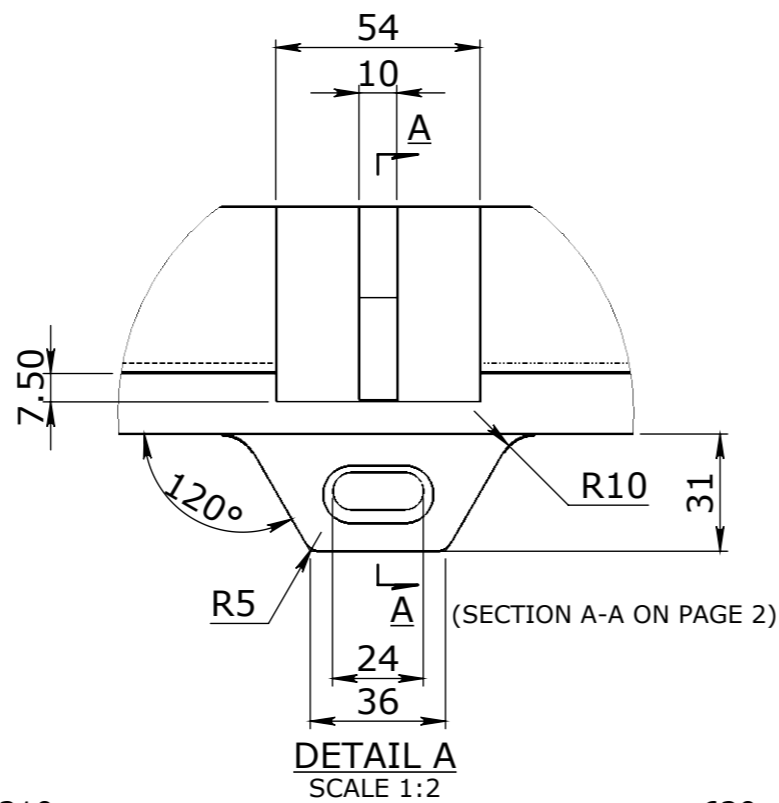

UNCONTROLLED DOCUMENT WHEN PRINTED

1. MATERIAL SPECIFICATIONS UNO SECTIONS & FLATS - AS 3679 - GR 300+ PLATES AS 3678 - GR 250 SHS AS 1163 - GR 350
 2. WELDING TO COMPLY TO AS 1554.1 UNO

Rev	DESCRIPTION	DATE:	BY:	ECO#:

CHK / APPR: **C. ABEYSINGHE**
 DATE: **06/09/2018**
 RPEQ DOCUMENT #:



HEAD OFFICE:
 CARNINGHAM ROAD
 BALLARAT, VIC 3351
 (03) 5335 8741
 ENGINEERING & DEVELOPMENT:
 2 STRADBROKE STREET
 HEATHWOOD, QLD 4110
 (07) 3714 0444

PROJECT DESCRIPTION:
CUBIS SYSTEMS AUSTRALIA CATALOGUE PRODUCTS
 DRAWING NAME:
MANHOLE SIDE MEMBER 1240mm

GENERAL TOLERANCES				
NOMINAL SIZE	UP TO 150	ABOVE 150 UP TO 500	ABOVE 500	ANGULAR ∠ X.X±0°30'
TOL	±1.0	±2.0	±5.0	∠ X ± 1°

TOLERANCES - FABRICATION		
LINEAR X.XX ± 0.02	FACES SQUARE ⊥ 0.05/100	ANGULAR ∠ X.X ± 0°30' DIA. CONC WITHIN Ⓞ0.05 TIR
LINEAR X.X ± 0.1	FACES PARALLEL// 0.05/100	ANGULAR ∠ X ± 1° EDGES CHAMFERED 1.0 x 45°
LINEAR X. ± 0.25	FACES FLAT ▱ 0.05/100	GENERAL SURFACE FINISH Ra $\sqrt{3.2}$

REVISION CONTROL		

WEIGHT: **Kg**
 MATERIAL:
 SURFACE TREATMENT:

THE INFORMATION DISCLOSED IN THIS DOCUMENT IS CONFIDENTIAL AND IS NOT WITHOUT THE EXPRESS CONSENT OF CUBIS SYSTEMS AUSTRALIA TO BE COPIED, REPRODUCED, OR GIVEN TO ANY OTHER PARTY IN ANY FORM AND THAT ALL COPYRIGHT, DESIGNS AND PATENTS VEST IN CUBIS SYSTEMS AUS.

DRAWING INFORMATION				
SHEET: A3	PAGE: 1/2	SCALE UNO: 1:5	DRAFTED DATE: 28/06/2018	DRAFTED BY:
DRAWN TO AS 1100 DO NOT SCALE FROM SHEET			DRAWING No: 50201033	REV: 0